



# Best Practice for the Safe Packing & Handling of Cargo to & from Offshore Locations

issue 6 | 2015



**Best Practice**  
(Formally known as Guidelines)  
**for the Safe Packing  
& Handling of Cargo  
to & from Offshore  
Locations**

ISSUE 6 | JANUARY 2015

Whilst every effort has been made to ensure the accuracy of the information contained in this publication neither Oil & Gas UK nor any of its members will assume liability for any use made thereof.

All rights reserved. No part of this publication may be reproduced, stored in a retrieval system, or transmitted in any form or by any means, electronic, mechanical, photocopying, recording or otherwise, without prior written permission of the publishers.

Crown copyright material is reproduced with the permission of the Controller of Her Majesty's Stationery Office.

Copyright © 2008 Oil & Gas UK

**ISBN:** 1 903003 32 6

**London Office:**

6th Floor East, Portland House, Bressenden Place  
LONDON, SW1E 5BH

Tel: 020 7802 2400

**Aberdeen Office:**

2nd Floor, The Exchange 2  
62 Market Street, ABERDEEN AB11 5PJ

Tel: 01224 577250

[info@oilandgasuk.co.uk](mailto:info@oilandgasuk.co.uk) | [www.oilandgasuk.co.uk](http://www.oilandgasuk.co.uk)

visit [www.onshoreoffshorecargo.com](http://www.onshoreoffshorecargo.com)

## **1.0 Preface**

## **2.0 Introduction**

## **3.0 Scope & Application**

## **4.0 Abbreviations**

## **5.0 References**

## **6.0 Responsibilities & Duties**

- 6.1 Vendors
- 6.2 Haulage Contractors
- 6.3 Logistics Service Providers
- 6.4 Vessel Operators
- 6.5 Aircraft Operators
- 6.6 Offshore Operators

## **7.0 Dropped Objects**

- 7.1 Checking for Dropped Objects
- 7.2 Verification of Checks  
(including In / Outbound Cargo Security Tags)
- 7.3 Dropped Objects Prevention Scheme (DROPS)

## **8.0 Lifting & Slings**

- 8.1 Lifting Operations
  - 8.2 Planning the Lifting Operation
  - 8.3 Undertaking the Lifting Operation
  - 8.4 Pre-Use Inspection and General Precautions
  - 8.5 Thorough Examination and Inspection of Lifting Equipment
- Appendix 8.A - Lifting Operations Categorisation and Controls Table
- Appendix 8.B - Drilling Tubulars
- Appendix 8.C - Special Cargo
- Appendix 8.D - Use of Tag Lines
- Appendix 8.E - Abnormal or Wide Load Matrix

## **9.0 Carriage of Goods by Sea**

- 9.1 Introduction
- 9.2 Responsibilities for Cargo Checks within the Supply Chain
- 9.3 General
- 9.4 Cargo Handling and Shipping Equipment
- 9.5 General Pre-shipment Inspection  
Checks for Open & Closed CCU's
- 9.6 General Checks for Specialist Equipment
- 9.7 Packing Cargo in CCUs
- 9.8 Closed Container – Key Points from Checklist
- 9.9 Open Container – Key Points from Checklist
- 9.10 Snagging Hazards
- 9.11 CCU Standards and Inspection Requirements
- 9.12 Marking

## **10.0 Dangerous Goods by Sea**

- 10.1 General
- 10.2 Sea Specific
- 10.3 Dangerous Goods in Machinery
- 10.4 Radioactives

Appendix 10.A - Dangerous Goods Flowchart - Inbound

Appendix 10.B - Class segregation table from IMDG Code

## **11.0 Carriage of Goods by Air**

- 11.1 Freight Classifications
  - 11.2 General Guidance and Freight Packaging
- Appendix 11.A - Oil & Gas UK Cargo Rejection Note - Air

## 12.0 Dangerous Goods by Air

- 12.1 General
- 12.2 Air Specific
- 12.3 Helideck
- 12.4 Radioactives
- 12.5 Samples

Appendix 12.A - Shippers Declaration For Dangerous Goods

## 13.0 Non Conforming Cargo

- 13.1 Pre-shipment Inspection Procedures
- 13.2 Cargo Unfit for Shipment
- 13.3 Non Conformance Code

Appendix 13.A – Non Conformance Code Checklist

## 14.0 General Documents & Forms

- 14.1 Oil & Gas UK Inbound Pocket Checklist - Tank
- 14.2 Oil & Gas UK Cargo Rejection Note - Air
- 14.3 Oil & Gas UK Inbound Pocket Checklist
- 14.4 Oil & Gas UK Cargo Summary Ticket For Outbound Cargo
- 14.5 Oil & Gas UK Cargo Summary Ticket For Outbound And Inbound Tanks
- 14.6 Oil & Gas UK Cargo Rejection Note - Sea
- 14.7 Abnormal or Wide Loads
- 14.8 Non Routine or Special Cargo Items Transportation to or from Site
- 14.9 Non Routine or Special Cargo Items Transportation to or from Site - Vendors Logistics Check List

## 15.0 Waste Management

- 15.1 Controlling Waste Offshore
- 15.2 Special Waste (Hazardous/Harmful)
- 15.3 Recyclable Waste



**Onshore CCU Packing & Handling**



**Forklift Operations**



**Transport**



**Gantry Inspections**



**Documentation & Checklists**



**Quayside Activities**



**Marine Operations**



**Offshore Activities**



**Offshore Installation**

## 1.0 PREFACE

An original workgroup comprising ASCO, BP Amoco (now BP), Gulf Offshore, Seaforth Maritime, Shell, Swire and Texaco was established by the Marine Safety Forum (MSF) to consider the hazards and risks associated with the safe packaging and handling of cargo to and from offshore installations. The objective of the workgroup was to identify areas where additional guidance would help to secure improvements in safety.

In accordance with the three-year review strategy, a new workgroup (see Cross Industry Workgroup section) was formed to develop the document beyond the original focus, taking into consideration changes in legislation, good working practices and learnings from incidents.

The group acknowledges the assistance given in the preparation of this guidance document by the following bodies:

- Chamber of Shipping (CoS)
- Health and Safety Executive (HSE)
- Helideck Certification Agency Ltd (HCA)
- International Association of Drilling Contractors North Sea Chapter (IADC)
- Maritime and Coastguard Agency (MCA)
- Oil & Gas UK

The safe carriage of goods relies upon the correct packaging, securing, labelling and handling procedures. Operators, logistics service providers, aircraft operators, shipping and vendor companies have produced this guidance, which provides practical advice. If there is doubt, the reader should always consult the primary reference.

Specific manual and mechanical handling activities associated with cargo handling are not included in this guidance. They should form part of individual company's Safety Management Systems.

In order to ensure the currency of these Industry Best Practices, the workgroup will meet to review them at intervals not exceeding three years, and reissue accordingly.

This revision 6 replaces revision 5 of November 2011.

## **2.0 INTRODUCTION**

This document should not be read in isolation and is supported by additional documents which are referenced in their relevant sections.

- 2.1 The main thrust of the document is to provide an overview of the best practices and key processes which are involved in the safe handling of cargo supported by appendices.
- 2.2 Alternative practices should only be adopted where they would specifically offer a greater level of safety.
- 2.3 Cargo both on and offshore will be subject to inspection checks.  
Non-conformance with this document WILL result in cargo NOT being forwarded until the necessary remedial actions have been carried out in conjunction with the relevant company.

### **3.0 SCOPE AND APPLICATION**

3.1 The purpose of this Best Practice document is to assist the following parties involved in the movement of cargo to or from offshore installations.

It recognises the hazards involved in the packaging and handling of cargo during normal operations, and to avoid or reduce the associated risks by the adoption of common industry standards:

- Vendors
- Haulage Contractors
- Logistics Service Providers
- Vessel Operators
- Aircraft Operators
- Offshore Operators

3.2 This document applies to the safe packing and handling of cargo to and from offshore locations in support of operations on the United Kingdom Continental Shelf (UKCS) or elsewhere if adopted.

3.3 Users of this document must pay regard to any relevant legislation or authoritative recommendations which have evolved subsequently to the date of publication or during the life of this edition. This document includes references to relevant legislation. See Section 5, References.

3.4 In the absence of appropriate legislation, relevant bodies may use this document to assist in their investigations.

## 4.0 ABBREVIATIONS

Initials	Description
ADR	Accord Dangereux Routiers (European Standard on Dangerous Goods Transportation)
BOP	Blow Out Preventer
BS EN	British Standard European Norm
CCU	Cargo Carrying Unit
CE	Conforms to a European Directive
CoG	Centre of Gravity
CoS	Chamber of Shipping
CSC	Cargo Security Certificate
CTU	Cargo Transporting Unit (also known as CCU)
DfT	Department for Transport
DGR	Dangerous Goods Regulations
DG	Dangerous Good
DNV	Det Norske Veritas
EA	Environment Agency
EWC	European Waste Catalogue
HCA	Helideck Certification Agency Ltd
HLO	Helicopter Landing Officer
HSE	Health and Safety Executive
IADC	International Association of Drilling Contractors (North Sea Chapter)
IATA	International Civil Air Transport Association
ICAO	International Civil Aviation Organisation
IMDG	International Maritime Dangerous Goods Code
IMO	International Maritime Organisation
LMC	Last Minute Change

<b>Initials</b>	<b>Description</b>
LOLER	Lifting Operations and Lifting Equipment Regulations
MARPOL	International Maritime Organisation Convention for the Prevention of Pollution from Ships
MCA	Maritime and Coastguard Agency
MCAA	Marine Competent Authority Approval
MEGC	Multiple Element Gas Container
MGN	Marine Guidance Note
MSF	Marine Safety Forum
NOTOC	Notification to Captain
NUI	Normally Unattended Installation
OIM	Offshore Installation Manager
PV	Pressure Vacuum
SADIE	Safety Alert Data Information Exchange
SEPA	Scottish Environmental Protection Agency
SWL	Safe Working Load
TPEC	Temporary Portable Equipment Certificate
TRIC	Task Risk Identification Checklist
OGUK	Oil and Gas UK
UKCS	United Kingdom Continental Shelf
VCOC	Vendor's Certificate of Conformity
WLL	Working Load Limit
WSCA	Well Services Contractors Association

## 5.0 REFERENCES

### References

Approval of Offshore Containers Handled in Open Seas Guidelines MSC/Circ 860

Carriage of Dangerous Goods and Use of Transportable Pressure Equipment Regulations [SI 2007/1573]

Code of Practice for Inspection and Repair of Offshore Containers BS 7072:1989

Code of Practice for the Safe Use of Wire Rope Slings BS 6210:1983

Dangerous Goods in Cargo Transport Units HSG 78

Department of Transport Code of Practice Safety of Loads on Vehicles

Environmental Protection (Duty of Care) Regulations [SI 1991/2839]

Hazardous Waste (England & Wales) Regulations [SI 2005/894]

HCA Procedure for the Shipment of Dangerous Goods from Offshore Installations and Vessels to Onshore by Helicopter

IATA (International Air Transport Association) Dangerous Goods

ICAO Technical Instructions for the Carriage of Dangerous Goods by Air

International Maritime Dangerous Goods (IMDG) Code

Lifting Operations and Lifting Equipment Regulations [SI 1998/2307] (LOLER)

LOLER Approved Code of Practice (HSE Books L113)

Marine Guidance Note MGN 282 (M)

Marine Guidance Note MGN 283 (M)

Merchant Shipping (Dangerous Goods and Marine Pollutants) Regulations [SI 1997/2367]

Merchant Shipping (Prevention of Pollution by Garbage) Regulations [SI 1998/1377]

Offshore Containers, Design, Construction, Testing, Inspection and Marking: BS EN 12079:2006, DNV 2.7-1

Offshore Freight Containers Design and Certification – DNV Certification Notes 2.7-1:1989

Special Waste Amended (Scotland) Regulations [SSI 2004/112]

Special Waste Amended (Scotland) Regulations [SSI 2005/22]

Specification for Wire Rope Slings and Sling Legs for General Lifting Purposes BS 1290:1983

Steel Wire Rope Slings, Safety, Slings for General Lifting Purposes BS EN 13414-1:2003

Step Change in Safety – Design and Handling of Cargo Baskets Guidance

---

Stowage of Goods in Freight Containers Guidelines BS 5073:1982

---

Temporary Portable Equipment Certificate [PE001]

---

Textile slings, Safety, Round-slings, made of man-made fibres, for general purpose use Guidelines BS EN 1492-1 Parts 1 and 2

---

Transport of Dangerous Goods and Use of Transportable Pressure Receptacles [SI 2004/568]

---

Transportable Gas Cylinders – Gas Cylinder Identification (excluding LPG) – Part 3 Colour Coding: BS EN 1089 – 3:2011

---

Transportable Gas Cylinders – Periodic Inspection and Testing of Seamless Steel Gas Cylinders BS EN 1968:2002

---

Waste Management Regulations [SI 1996/634]

---

Well Handled – Offshore manual handling solutions HSG 171

---

Oil & Gas UK Offshore Support Vessel Guidelines

---

## Internet References

UK Statutory Instrument Web site

[www.legislation.hmso.gov.uk/stat.htm](http://www.legislation.hmso.gov.uk/stat.htm)

---

British Standards Web site

[www.bsonline.bsi-global.com/server/index.jsp](http://www.bsonline.bsi-global.com/server/index.jsp)

---

Maritime and Coastguard Agency Web site

[www.mcga.gov.uk](http://www.mcga.gov.uk)

---

Step Change Standard Lifting and Crane Operating Procedures Group

[www.stepchangeinsafety.net](http://www.stepchangeinsafety.net)

---

Health and Safety Executive Home Page

[www.hse.gov.uk/hsehome.htm](http://www.hse.gov.uk/hsehome.htm)

---

Chamber of Shipping

[www.british-shipping.org](http://www.british-shipping.org)

---

Oil & Gas UK

[www.oilandgasuk.co.uk](http://www.oilandgasuk.co.uk)

---

Marine Safety Forum

[www.marinesafetyforum.org/about.asp](http://www.marinesafetyforum.org/about.asp)

---

## **6.0 RESPONSIBILITIES & DUTIES**

All parties involved in the supply chain have an obligation to ensure that cargo is properly packaged, prepared and secured for the duration of its journey to or from the offshore location, this includes the following:

- Vendors
- Haulage Contractors
- Logistics Service Providers
- Vessel Operators
- Aircraft Operators
- Offshore Operators

Successive parties in this chain are responsible for maintaining the integrity of the cargo.

To ensure compliance with this document, scheduled Safe Cargo Handling Audits may be undertaken by any of the parties listed above. An audit questionnaire is available within this document.

Vendors and their subcontractors are responsible for ensuring that cargo is prepared for shipment throughout its entire journey in compliance with relevant legislation and this document.

Cargo Summary Tickets (see 14.4 to 14.5) must be fully completed at the start of the cargo's journey. The Cargo Summary Tickets must be completed and signed by the person responsible, at the vendor's premises, for packing and preparing the cargo for its journey to or from the offshore location. Where there are multiple truckloads, one copy is to accompany each truck with the relevant items highlighted.

Yellow Cargo Safety and Security Tags as recommended by STEP Change in Safety (see Appendix 7.5) may be used in addition to Cargo Summary Tickets as a visual indicator that cargo has been checked and is packed in accordance with the Cargo Summary Ticket.

Vendors and their subcontractors must ensure that all applicable documentation accompanies the shipment, e.g. Temporary Portable Equipment Certificate (TPEC), Vendor's Certificate of Conformity (VCO) or equivalent.

Non-conformance with this document WILL result in cargo being rejected. See Section 13, Non-Conforming Cargo.

### **6.2 Haulage Contractors**

#### **6.2.1 General**

Haulage contractors are responsible for ensuring that drivers have the necessary competency levels for the task to be undertaken and that vehicles plus accessories are fit for the intended purpose.

They must therefore ensure that:

- i. Vehicles are suitable for the intended purpose, display the appropriate hazard warning panels and carry the requisite fire fighting equipment.

- ii. Drivers are provided with all other safety equipment that may be required in the event of an emergency involving the goods being transported. Such equipment may include, but is not restricted to, first aid equipment, protective clothing, etc.
- iii. During loading or discharge of cargo the driver, in conjunction with the plant operator, agrees the location of the safe haven and remains there until the operation is completed. Drivers should not remain in their cabs if this can be avoided. No person should be in the loading/unloading area if they are not needed. However there are times when the driver may be required to act as a 'spotter' to assist the forklift driver. The driver will position himself toward the back of the trailer (away from danger) and highlight any snagging hazards during offload of cuttings bins or gas racks. This follows incidents where these items are pulled off trailers as a result of snagging.
- iv. Drivers are provided, by customer/vendor in writing, with the mandatory transport information about the goods to be carried. Additionally, if the goods are classed as dangerous they must have a good understanding of the nature of the hazards and appropriate action to be taken in an emergency, and must possess an ADR qualification.
- v. Drivers must not accept any cargo manifested for offshore without the appropriate documentation and in particular Cargo Summary Tickets.
- vi. There is a storage space in the cab for this detailed information.
- vii. Drivers are trained to use the emergency equipment provided.
- viii. Drivers are adequately trained and instructed regarding their duties under ADR Regulations and, if required, are in possession of a valid certificate of training relevant to the task being performed.
- ix. Further guidance can be obtained in Dangerous Goods in Cargo Transport Units HSG 78.

**Note:** The contractor must ensure compliance with the Carriage of Dangerous Goods and Use of Transportable Pressure Equipment Regulations [SI 2007/1573], including the provision of a competent attendant where appropriate.

### 6.2.2 Dangerous Goods

Drivers must:

- i. Ensure that information about previous loads or substances carried has been destroyed, removed or kept in a securely closed container.
- ii. Keep the written information about the dangerous goods readily available throughout the journey.
- iii. Ensure precautions are available against fire, explosion or any other incident throughout the journey. This includes checking the fire extinguishers, normally on a daily basis.
- iv. Ensure appropriate hazard warning placards are available, accessible and legible.
- v. Ensure loads are properly secured on the vehicle (Department for Transport Code of Practice Safety of Loads on Vehicles 3rd edition provides guidance).
- vi. Leave unattended vehicles only in a designated parking area.

## 6.2.3 Securing and Safety of Loads

6.2.3.1 The driver is responsible for the safety and security of any load whilst it is on the vehicle and as far as reasonably practical should ensure that there are no loose objects on any cargo carried.

Safety and security of cargo being returned to vendors is the responsibility of the logistics service provider. Where several cargoes are carried on the same vehicle factors to be taken into account in planning the route must include:

- i. Compatibility of materials carried
- ii. Order of discharge

Forward planning will minimise risks associated with off-loading vehicles.

6.2.3.2 The method of securing the cargo on the vehicle will depend on the load being carried. When containers are being carried the following factors shall be taken into consideration:

- i. Twist locks are the preferred means of securing the items.
- ii. Where twist locks are not used, a minimum of two restraints per container must be used, ensuring the combined Safe Working Load (SWL) of the restraints in the configuration applied exceeds the weight of the cargo. Haulage Contractor may apply a third restraint to a unit that encroaches within the last 3ft of the trailer.

Local rules which have been subject to thorough Risk Assessment may, however, be applied to site transportation.

- iii. Container door(s) should be closed and the closing mechanism secured so that it cannot inadvertently open during handling and transport.
- iv. Empty Cargo Carrying Units (CCUs) specifically designed for the purpose may be stacked for road transport when compatible. Attention is drawn to the possibility that units that appear similar may not be compatible, and due care should be taken. Where CCUs are not designed to be stacked but nevertheless require road transportation in a stacked manner, a Risk Assessment must be performed which should include, but is not limited to:

- the CCU is empty
- no metal to metal contact
- substantial dunnage is used
- strapping is in excess of the normal requirements
- where necessary, trailer stanchion pins are fitted

6.2.3.3 Lashing material will depend on the weight to be secured. Polyester cargo restraints will be sufficient for the majority of cargo but extremely heavy loads may have to be secured using high tensile chains and ratchet style load binders.

6.2.3.4 To minimise hazards to other road users, lifting sets should always be adequately secured while cargo is being transported. Where container lifting arrangements include a fifth leg, it shall also be secured.

- 6.2.3.5 When transporting tubulars they should, wherever possible, be “butted up” to trailers with steel headboards. The load shall be suitably secured, not exceeding the height of the headboard.

To ensure stability of the load, trailer pins should be fitted at the sides of the trailer and secure wedges employed where necessary. As each tubular bundle is landed the slings should be laid along the length of the bundle to prevent them being crushed by the next bundle. This will also simplify off-loading.

- 6.2.3.6 The weight of all items of cargo being carried must be known. Consignees should be notified in advance of any items (7 tonnes or over) defined as heavy lifts in order that the necessary arrangements for transporting and receiving the cargo can be made. Heavy lifts are defined in section 8.4.11.
- 6.2.3.7 Unstable objects will require special arrangements. Securing arrangements for such items should not be removed until the lifting equipment has been attached and tensioned in preparation for removal from the vehicle.

### **6.3 Logistics Service Providers**

Logistics service providers are responsible for the safety of personnel and cargo during quayside operations, and for the safe loading or discharge of vessels whilst in port. Where service provision includes warehousing and central packing, see comments in Vendors Section 6.1.

During loading or discharge of cargo the Plant Operator, in conjunction with the Driver, agrees the location of the safe haven and the Driver remains there until the operation is completed.

Logistics service providers shall ensure that the vessel deck area occupied by cargo does not exceed utilisation factors, previously agreed with Vessel Master and charterers.

Loading should be in accordance with the installation’s specific quayside shipping instructions.

Due consideration should be given to known discharge priorities for the cargo on that voyage in order to prevent “Cherry Picking”.

### **6.4 Vessel Operators**

The Master of a vessel is responsible for the safety of the crew and vessel at all times and has authority to decide whether operations affecting the vessel should proceed or be terminated.

- 6.4.1 The vessel Master is responsible for the safe and correct loading of his vessel. He should liaise with the Logistics Service Provider to ensure that the vessel is loaded correctly and in accordance with the Charterer’s specific requirements.

The Master shall ensure that the deck area occupied by cargo does not exceed agreed utilisation factors.

- 6.4.2 In conjunction with the base operator, vessel Deck Crew should ensure the lifting equipment is readily available for handling at point of discharge, with particular attention to half height open top containers.

The vessel Deck Crew should make a final visual check to ensure the lift is safe prior to the hook being attached to the load for discharge offshore.

- 6.4.3 The Logistics Service Provider or Offshore Materials Coordinator must provide the vessel with a copy of the loading list complete with all relevant Dangerous Goods information for each installation to be visited and also an accurate manifest. These documents must be received in sufficient time to permit proper stowage of the cargo for the route envisaged.
- 6.4.4 The IMDG Code contains internationally agreed recommendations for the safe transport of dangerous goods by sea. Although primarily aimed at vessel operators, the Code requirements affect everyone involved in the transport chain, from the manufacturer of the dangerous goods through to the consumer.
- The MCA issues regulations relating to the transportation of dangerous goods on offshore support vessels within the UKCS.

## 6.5 Aircraft Operators

The Captain of the aircraft is responsible for the safety of the passengers and aircraft at all times and has authority to decide whether operations affecting the aircraft should proceed or be terminated.

- 6.5.1 The aircraft Captain is responsible for the safe and correct loading of his aircraft. He should liaise with the HLO or onshore equivalent to ensure that the aircraft is loaded correctly.
- 6.5.2 The HLO or onshore equivalent must provide the Captain with a copy of the manifest complete with all relevant Dangerous Goods information. These documents must be received in sufficient time to permit proper planning of the flight.
- 6.5.3 The IATA Dangerous Goods Regulations contain information on the safe transport of dangerous goods by air.
- 6.5.4 The Captain of an aircraft must be supplied with information concerning any Dangerous Goods placed aboard his aircraft. This is a “Notice to Captain” or “NOTOC”, and this function is carried out by either the operator or an agent.

**Note:** Offshore - a person providing the information is acting as the helicopter operator's agent and the captain will need to see and keep a copy of the completed checklist, and may need to view a copy of the qualified person's acceptance certification.

## 6.6 Offshore Operators

The OIM is responsible for the safety of the Offshore Installation, all personnel on board and for safe cargo handling operations.

- 6.6.1 Offshore Operators are responsible for ensuring that cargo is prepared for shipment throughout its entire journey in compliance with relevant legislation and this document.
- 6.6.2 Cargo Inbound Pocket Checklists (see 14.1 and 14.3) should be fully completed at the start of the cargo's journey. The Cargo Inbound Pocket Checklist to be completed and signed by the person, at the installation, responsible for checking the packaging and preparation of the cargo for its journey back to the vendor's premises.

- 6.6.3 Alternatively, inbound orange, as recommended by STEP Change in Safety, or interfield green Cargo Safety and Security Tags (see 7.2) may be used as a visual indicator that cargo has been checked and is packed in accordance with the Cargo Inbound Pocket Checklist.
- 6.6.4 Non-conformance with this document WILL result in cargo being rejected. This may result in delays or other problems in the onward shipment of the cargo.
- 6.6.5 All non-conformances will be formally documented and written resolution required from the offending location.

“

All parties involved in the supply chain have an obligation to ensure that cargo is properly packaged, prepared and secured for the duration of its journey to or from the offshore location.

”

## 7.0 DROPPED OBJECTS

Dropped objects continue to be a major health and safety issue within the industry.

A dropped object can be defined as any loose item found on cargo which is not properly restrained and therefore has the potential to fall off whilst in transit by road or sea.

Common examples of potential dropped objects are hand tools which have been used in preparation of the lift, debris, stones, and even ice.

The law of physics dictates that even the smallest nut can have a devastating effect when it falls from height on to a person handling cargo on the deck of a supply vessel. Similarly, a loose object falling from a travelling truck could have disastrous results to other road users.

### 7.1 Checking for Dropped Objects

At every stage of the supply chain, the following checks should be taken to mitigate the risk of potential dropped objects:

- i. Check all forklift pockets (transverse and longitudinal) for loose objects or debris.
- ii. Check top of all lifts.
- iii. Check all horizontal and vertical surfaces including grating floors e.g. gas racks.
- iv. Check within and around the structure of open framed lifts.
- v. Check tanks to ensure all valve caps are closed and secured.
- vi. Check bundles of pipe externally and internally and that protectors are properly fitted.
- vii. Ensure thread protectors and end-caps are securely fastened.
- viii. Ensure contents are properly secured to prevent items escaping during transit.

Any potential dropped objects that are found must be removed prior to transportation

## DO'S AND DON'TS

### Do's

- Accept responsibility for ensuring cargo integrity
- Intervene when you eyeball potential hazards
- Ensure the operatives / deck crews packing the containers and doing the checks understand the full importance and implications of signing the Cargo Summary Ticket (CST).
- Pre road checks - Requirement for Inspections carried out at the exit to our facilities.
- Close the loop with gantry inspectors on their documented observations and what the operator has done with their vendor to reduce future similar reoccurrences.

## DON'TS

- Accept pre-printed CST's at gantries or shipping desks. (Especially pre-printed signatures)
- Rely on the contract managers / reps to deliver the message completely to the individuals
- Assume all checks are made by others
- Accept pre-printed CST's at gantries or shipping desks. (Especially pre printed signatures)
- Rely on the contract managers / reps to deliver the message completely to the individuals

## 7.2 Verification of Checks

To verify that the CCU has been fully checked for potential dropped objects it is a mandatory requirement that the applicable section of the Cargo Summary Ticket is completed for all outbound cargo and the Cargo Inbound Pocket Checklist is completed along with the Backload Tag completed and attached to the CCU for all inbound cargo. Please refer to Section 9.0 Carriage of Goods by Sea



## 7.3 Dropped Objects Prevention Scheme (DROPS)

To access detailed information and best practices regarding dropped objects please visit the following web site [www.dropsonline.org](http://www.dropsonline.org).



This picture was from an actual event where a dropped object from Offshore fell from a travelling truck and went through the windscreen of a car, it narrowly missed the mother and landed beside the child in the child seat on the back seat of the car.

Both escaped serious injury ...

... it could've been your wife and child!

## Examples of Potential Dropped Objects



## **8.0 LIFTING AND SLINGING**

### **8.1 Lifting Operations**

All lifting operations performed and the lifting equipment utilised must satisfy the requirements of the Lifting Operations and Lifting Equipment Regulations [SI 1998/2307] (LOLER). Specific guidance on complying with these Regulations is offered in the LOLER Approved Code of Practice (HSE Books L113).

The Duty Holder for any site where lifting operations are performed will have, in their Safety Management System, documented procedures which will ensure that the requirements of LOLER are met.

“Duty Holder” means:

1. In relation to a fixed installation, the Operator
2. In relation to a mobile installation, the Owner

These guidelines are not intended to replace any procedures enforced by a Duty Holder but offer minimum criterion to assist personnel when planning or executing lifting operations

### **8.2 Planning the Lifting Operation**

The degree of planning will depend upon the type of the lifting operation to be undertaken. Reference must be made to the Duty Holders documented procedures for LOLER compliance. An approach, which is frequently adopted, is to classify the lifting operation as either routine or non-routine.

Routine lifting operations are those that are frequently undertaken and will generally include all normal cargo operations. Documented procedures will have been developed for each of these routine lifts based upon a Risk Assessment and a lifting plan. Each time the operation is to be performed reference will be made to the procedure and all personnel involved in the lifting operation prior to performing the task will discuss this at the toolbox talk. Procedures must be kept under review to ensure that they remain valid.

In the case of a non-routine lifting operation this will need to be planned by a competent person, be subjected to a Risk Assessment and the method be detailed in a written lifting plan. The Duty Holder’s LOLER compliance document will specify the competent person(s) who perform this function.

Further guidance on lifting operations is shown in a typical Lifting Operations Categorisation and Controls Table, see:

Appendix 8.A – Lifting Operations Categorisation and Controls Table

### 8.2.1 Supervision of the Lifting Operation

The degree of supervision is dependent upon the type of lifting operation to be undertaken and is therefore proportionate to the risk.

For routine operations, dedicated supervision of the operation may not be required but a competent person must be in control of the operation. This competent person will co-ordinate and control all aspects of the lifting operation, for example this person could be the Banksman. In addition someone will also need to be in control of the toolbox talk, to ensure all the personnel are aware of the task, the documented procedures to be followed and their responsibilities.

Non-routine operations will always require supervision and this will probably be undertaken by the competent person who has undertaken the Risk Assessment and produced the lifting plan.

### 8.2.2 Competence and Training

Reference must be made to the Duty Holder's LOLER compliance document which will detail the level of both training and competence for lifting personnel.

### 8.2.3 Classification of Lifting Operations

The classification of the lifting operation to be performed is an essential part of the planning activities. How this is undertaken will be documented in the Duty Holder's LOLER compliance document, but all planned lifting operations will need to be classified by a competent person. It is important that this person continually reviews all operations, as there will be factors that may change the operation from being a routine into a non-routine activity.

This person will probably be the same as the one who produces the lifting plans and will identify, for example, certain types of loads which have an unusual lifting geometry, or be inherently unstable, or have other unusual characteristics.

Such lifts may include:

- i. Loads with the centre of gravity above the lifting points.
- ii. Loads with an offset centre of gravity.
- iii. Loads with a narrow or small base.
- iv. Extremely long loads that tend to rotate.

Refer to Appendix 8.C for further Special Cargo instructions and Appendix 8.D for transport of Abnormal or Wide Loads.



### 8.3 Undertaking the Lifting Operation

Prior to carrying out any lifting operation certain precautions shall be observed.

They are applicable to any lifting operation and include holding a toolbox talk at which the details of the task are discussed.

This will include for routine lifts the documented procedures and in the case of non-routine lifts the Risk Assessment and lifting plan. Specific responsibilities will be allocated to nominated persons at the toolbox talk, including the identification of the competent person who will co-ordinate and control all aspects of the lifting operation.

The nominated person(s) will:

- i. Ensure at all times that the load does not pass over personnel.
- ii. Ensure that a clear and effective communication system is employed and understood by all personnel involved with the lifting operation.
- iii. Ensure there is adequate lighting in the pick-up and lay-down areas and effective and unobstructed access ways and escape routes exist.
- iv. Ensure the lifting equipment is certified for current use.
- v. Ensure any restrictions to the lift are removed, e.g. hold-down bolts, sea fastenings.
- vi. Confirm that the appropriate rigging for the lift is correctly installed and the lifting sets are not twisted or snagged.
- vii. Ensure shackle bolts are tight and adequately secured.
- viii. Ensure pick-up and lay-down areas are within the allowable crane radii for the load being lifted.
- ix. Confirm the weight of any particular load or bundle. This should be confirmed when a load is stationary and all load cells used for this purpose should be calibrated on a 12 monthly basis, as a minimum.
- x. Ensure the hook is positioned above the load's centre of gravity.
- xi. Ensure only one CCU is lifted at any one time.
- xii. Ensure slings of equal length are used when handling tubulars.
- xiii. Ensure the load lifts horizontally.
- xiv. Ensure that the operation is controlled from a position with an unobstructed view. If at any stage the view becomes obstructed, the job should be stopped while the Banksman re-positions.

Should any doubt exist concerning the stability or security of any load the competent person for planning lifting operations must be consulted.

Refer to Appendix 8.B – Drilling Tubulars for details when shipping drilling tubulars.

## 8.4 Pre-Use Inspection and General Precautions

In each and every case where lifting equipment is to be employed it must be checked for defects in arrangements and/or physical damage, before use by the person in direct charge of the operation to comply with LOLER.

The employer must ensure that their personnel have received appropriate training and instruction to carry out these checks. Trained personnel must be able to identify damage to the elements of the equipment and accessories, distortions and other obvious faults that could affect the safe operation and use of the equipment.

### 8.4.1 General Precautions

Checks prior to the attachment and use of slings and shackles include:

- i. Confirm that the sling has a visible unique number and Safe Working Load (SWL) mark.
- ii. Examine for wear, corrosion, abrasion and mechanical damage, which may render the sling(s) unsafe.
- iii. Check that the sling set is correctly fitted, e.g. no twists in the legs.
- iv. Check that pin size and type is correct for the type of shackle.
- v. Check that the appropriate securing arrangements are installed (split pins, wire housing, etc.). R clips should not be used for this purpose.

The preferred style of shackle is the bow or anchor type fitted with a safety pin, which is, bolt, nut and split pin. The bolt or pin shall be of the same material as the body of the shackle.

**Note:** Screw pin type shackles will only be accepted if they have been secured with a steel serving / seizing wire. No alternative solutions will be accepted.

The crane hook link (master-link) must have a minimum dimension of 270mm x 140mm (specification for Wire Rope Slings and Sling Legs for General Lifting Purposes, BS EN 12079) to minimise the risk of trapped fingers when attaching the hook to the lifting arrangements.

### 8.4.2 Lifting Arrangements – CCUs

CCU Lifting arrangements almost universally consist of either wire or chain sling sets made up using appropriate connection arrangements.

Each form of rigging type has advantages and disadvantages. It is important that users understand the particular features and risks associated with each.

Arrangements incorporating wire slings are preferred in the UK, Irish, Danish and Dutch waters, those which include chain are preferred in the Norwegian sector and also elsewhere.

Guidance in the use and inspection of arrangements made up using each type of sling are included in the following sub-sections.

### 8.4.3 Wire Slings – General Precautions

General precautions when using lifting arrangements made up using wire slings include:

- i. All sling legs, which are connected directly to master-links or to shackles, should have thimbles fitted to reduce the bend radius on the wire and increase their serviceable life.
- ii. To avoid out-of-plane forces, the maximum number of lifting legs allowed on a single master link or ring is two. It is permissible to have a third leg on this ring, but only if it is to be used as a top lifting leg. Three and four leg lifting slings should be fitted to quadruple assemblies, i.e. a main lifting ring with two sub-links.
- iii. CCUs should be fitted with either a four or five leg lifting assembly with master link, depending on CCU type. The fifth leg is designed to hang over the side of the unit to assist in its hook-up, eliminating the need for personnel having to climb on top of containers to attach or release the crane hook.
- iv. This fifth leg is not a design requirement, but it is a preferred option and, if fitted, should “fall short” of the height of the CCU to facilitate connection and release of the hook. If the dimensions of the CCU are such that the fifth leg would present a snagging hazard at other stages of the supply chain, the fifth leg should be omitted.
- v. There is a recommended minimum wire rope diameter of 13mm allowed for wire rope slings. Operationally, it may be necessary to use wire rope of a smaller diameter however, wire rope of a smaller diameter is susceptible to impact damage and appropriate checks should be carried out.

#### Pre Use Inspection

Check that the SWL is adequate for the load.

Check that the sling has a plant number / ID mark.

Examine each individual leg along its entire length and check for:

- i. Wear
- ii. Corrosion
- iii. Abrasion
- iv. Mechanical Damage
- v. Broken Wires
- vi. Internal Deterioration (only if wire rope is suspect e.g. excessive external corrosion).

Check that the end of the loop does not terminate inside the ferrule (i.e. the rope end should protrude slightly but no more than 1/3rd of the diameter) unless the ferrule is of the longer tapered design which has an internal step.

The ferrule should be free from cracks or other deformities.

Examine each thimble and check for correct fitting, snagging damage and elongation (stretched thimbles / eyes could indicate possible overload).

Examine wire rope around thimbles as it is often abraded due to sling being dragged over rough surfaces.

Examine master-link/quadruple assembly and check for wear, corrosion and cracking.

If fitted with hooks, check for wear, corrosion and cracking and ensure safety latch functions.

#### **8.4.4 Chain Slings – General Precautions**

General precautions when using lifting arrangements made up using chain slings include:

- i. All arrangements are correctly certified in accordance with the relevant legislation (BS EN 818-4).
- ii. Chains and components employed in the make-up of the arrangements are constructed from alloy grade 8 (or better), and have properties suitable for working in extremely cold conditions (-20 °C).
- iii. All connections are compatible and fit for the purpose intended.
- iv. Agreement is obtained from all the parties involved.

##### **Pre Use Inspection**

Check that the SWL is adequate for the load.

Check that the sling has a plant number/ID mark.

Visually examine the chain sling along its entire length and check for:

- i. Distortion in chain links (nicks, bends, twists, elongated links)
- ii. Wear between chain links
- iii. Wear between chain links and load pins
- iv. Heat damage
- v. Chemical damage
- vi. Wear, stretch, and twisting on end terminations (including shortening clutches if fitted)
- vii. Function of safety catches (where fitted)
- viii. Security of load pins.

#### 8.4.5 Webbing Slings – General Precautions

Certified webbing (or fibre) slings, with adequate site control, are suitable for particular lifting operations at the worksite or on board an installation.

Such slings should not normally be used as the primary means of lifting from or to vessels unless the operation has been the subject of a thorough Risk Assessment.

Pre Use Inspection

Check that the SWL is adequate for the load.

Check that the sling has a plant number/ID mark.

Visually examine web sling along its entire length and check for:

- i. Cuts or tears
- ii. Burst stitching (especially around the eyes)
- iii. Chemical damage
- iv. Heat damage
- v. Ingress of foreign bodies into fibres
- vi. Distortion/wear in metal eyes (where fitted).

**Note:** When checking round slings, should any cuts be found in the outer protective cover, the sling should be condemned i.e. do not use as the inner strength core could be damaged.

#### 8.4.6 Shackles – Pre Use Inspection

- i. Check that the WLL is adequate for the load.
- ii. Check that the shackle has a plant number/ID mark.
- iii. Remove shackle pin (if accessible) and examine for wear, deformation and cracking.
- iv. Ensure it is the correct pin for the shackle.
- v. Check pin threads for wear/deformation.
- vi. Examine shackle body and check for wear in the crown and pin holes, deformation and cracking.
- vii. Check alignment of pin holes and ensure the pin fits correctly.
- viii. In the case of safety pin shackles, ensure split pins are fitted.

## Examples of Uneven Lifts



#### **8.4.7 Master Links and Quadruple Assemblies – Pre Use Inspection**

Check that the SWL is adequate for the load.

Visually examine master link(s) along its entire length and check for:

- i. Wear
- ii. Distortion
- iii. Elongation
- iv. Cracks
- v. Excessive corrosion

**Note:** Where possible, lifting arrangements for all cargo should be consolidated into a single lift point terminating in either a master link or quadruple assembly to minimise handling requirements, multiple terminations are not normally acceptable and may require duty holder approval

#### **8.4.8 Fabricated Items**

Where fabricated items include integrated lifting points and are not supported by a CE declaration of conformity, written documentation from a certifying authority that they are 'fit for the purpose' shall be forwarded to the handling agent.

#### **8.4.9 Transit Slings**

Transit slings are used for the transportation of equipment to and from offshore installations and onshore sites and should only be used for this purpose; they should not be used for general lifting purposes, as they are not part of the installation's lifting equipment.

A formal system is required to manage the use of transit slings to ensure that they comply with all relevant legislation and can be identified.

#### **8.4.10 Plastic Coated Transit Slings**

Plastic coated transit slings may be used for transporting easily damaged items, subject to thorough Risk Assessment which must take into account seasonal factors, such as low temperature cracking of plastic sheathing. These slings must be subject to the same controls as normal transit slings.

#### **8.4.11 Heavy Load Identification**

If the load is seven (7) tonnes or over it should be considered as "HEAVY" and identified as such by means of a pennant / flag. This pennant / flag must be attached prior to any transportation to quay side and fitted to the fifth leg or close to the master link assembly of the lifting set.

Although seven tonnes is a normally accepted standard, certain locations may have a higher or lower heavy lift threshold. Location specific information should be provided by the offshore operator.

Particular care must be taken when shipping to or from small, normally unattended installations.

#### **8.4.12 Use of Tag Lines**

If it is considered necessary tag lines shall only be used after a Risk Assessment has been undertaken, see Appendix 8.D – Use of tag lines

#### **8.5 Thorough Examination and Inspection of Lifting Equipment**

A “thorough examination” is a visual inspection carried out by a competent person. The competent person should also decide if any tests are to be carried out enabling them to verify any findings.

Lifting Appliances shall be inspected at intervals of no more than 12 months

Lifting Accessories shall be inspected at intervals of no more than 6 months

Any Lifting Equipment used for lifting personnel shall be examined at intervals of no more than 6 months

Lifting equipment may also be examined in accordance with a Written Scheme of Examination (see below)

##### **8.5.1 Written Scheme of Examination**

A written scheme of examination may be drawn up by the user or owner provided they have the necessary competence.

The scheme should specify the intervals at which the lifting equipment should be thoroughly examined. Any examination scheme for lifting equipment should take into account the lifting equipment’s condition, the environment in which it is used, the number of operations and the nature of load the equipment will be subject to.

If a written scheme of examination is to be used, it is essential that the user or owner is able to produce the examination scheme if requested by an inspector from the relevant enforcing authority.

If the user or owner is unable to produce the examination scheme, the enforcing authority will assume that the specified examination period laid down in LOLER has been followed.

##### **8.5.2 Colour Coding of Lifting Equipment**

Colour codes, although not a legal requirement are frequently used to indicate the examination status of lifting equipment in use on a particular site.

Where such arrangements are in use the current colour, indicating that the examination certificates of any lifting equipment bearing this colour is “in date”, should be conspicuously displayed immediately adjacent to the work site.

- Risk Assessment is undertaken
- A written procedure exists and is reviewed for this lifting operation
- Toolbox Talk Held
- Individual responsibilities allocated
- Carried out by competent personnel
- Supervised by Competent Person

## APPENDIX 8.A – LIFTING OPERATIONS CATEGORISATION AND CONTROLS TABLE

### Lifting operations controls table

- Responsible person identifies operation to take place.
- Competent person identifies lift category and implements control measures as detailed below:

	Categories of Lift	Control Measures
<b>Routine</b>	<p>Routine Lifting Operations</p> <ul style="list-style-type: none"> <li>• Uncomplicated lifts that are performed on a regular basis which involve basic slinging practices</li> </ul>	<ul style="list-style-type: none"> <li>• Risk Assessment is undertaken</li> <li>• A written procedure exists and is reviewed for this lifting operation / the method is documented in Rigging and Lifting Handbook</li> <li>• Toolbox Talk Held</li> <li>• Individual responsibilities allocated</li> <li>• Carried out by competent personnel</li> <li>• Supervised by Competent Person</li> </ul>
<b>Non routine</b>	<p>Simple or Basic Lifting Operation</p> <ul style="list-style-type: none"> <li>• Standard single line of rigging used directly above load</li> <li>• Only certified lifting points are used out with sensitive, difficult or restricted area</li> </ul>	<ul style="list-style-type: none"> <li>• Risk Assessment is undertaken</li> <li>• A procedure is written and approved by the LOLER Competent Person or Appointed Authority</li> <li>• Toolbox Talk Held</li> <li>• Individual responsibilities allocated</li> <li>• Carried out by competent personnel</li> <li>• Supervised by Competent Person</li> </ul>
	<p>Complicated Lifting Operation</p> <ul style="list-style-type: none"> <li>• For example awkward shape or high C.O.G</li> <li>• Extended duration, e.g. more than one shift</li> <li>• Use of two or more lifting appliances i.e. tandem lifts or cross hauling required</li> <li>• Within sensitive, difficult or restricted area</li> </ul>	<ul style="list-style-type: none"> <li>• Risk Assessment is undertaken</li> <li>• A procedure is written and approved by the LOLER Competent Person or Appointed Authority</li> <li>• Toolbox Talk Held</li> <li>• Individual responsibilities allocated</li> <li>• Carried out by competent personnel</li> <li>• Supervised by Competent Person</li> </ul>
	<p>Complex or Specialised Lifting Operation</p> <ul style="list-style-type: none"> <li>• Lifts that involve additional hazards due to the nature of the surrounding environment e.g. over live plant, within a confined space</li> <li>• Lifts requiring additional engineering input</li> <li>• Lifts where personnel are the load</li> </ul>	<ul style="list-style-type: none"> <li>• Impact/Hazard Study undertaken</li> <li>• Risk Assessment is undertaken</li> <li>• A procedure is written and approved by the LOLER Competent Person or Appointed Authority with the assistance of onshore engineering</li> <li>• Toolbox Talk Held</li> <li>• Individual responsibilities allocated</li> <li>• Carried out by competent personnel</li> <li>• Supervised by Competent Person</li> </ul>

## APPENDIX 8.B – DRILLING TUBULARS

This category includes items, such as drill pipe, risers, conductor, casing and tubing.

### 8.B.1 General

The following principles apply to both individual and bundled tubulars. However they do NOT apply where dedicated or bespoke lifting points have been provided as attachment points for the slings.

- 8.B.1.1 Each tubular lift must always be slung with two slings, each of the same length and of the same SWL. The SWL of each sling should be equal to or greater than the Gross Weight of the load. Every tubular lift must lift level.
- 8.B.1.2 Slings should be placed at equal distance (approximately 25%) from the ends of the load with the internal angle at the hook not greater than 90°. They should be double wrapped and choked around the tubular. When it is necessary to bundle tubulars of different lengths, the shortest tubular should be no less than 75% of the length of the longest tubular.
- 8.B.1.3 In the case of slung tubulars a wire rope grip (DIN 1142 type preferred) or other approved device should be used above the reeved eye that forms the 'choke'. In addition a tie wrap of robust design should be used on the reeved eye of the sling to prevent the eye from slipping over the rope grip. This arrangement prevents the bundle from coming slack when it's landed.

**Note:** The live end of the sling should not be threaded under the first wrap.

- 8.B.1.4 Excessively long tubular lifts may have a tag line attached. This should be subject to a Risk Assessment.
- 8.B.1.5 Care should be taken on removing slings due to possible stowage movement.
- 8.B.1.6 Tubular 'stacks' should be segregated by pipe posts.
- 8.B.1.7 The bottom row of a tubular stow should be individually 'choked' at positions forward and aft ends of each joint or secured by other mechanical means to stop movement. This also applies if there is only one row of tubulars.
- 8.B.1.8 In preparing tubulars for transportation it is good practice to pick up the tubular lift for a second time to see if more slack can be taken out using clamps or bulldog clips.
- 8.B.1.9 The offshore operator may have a requirement for tubulars to be loaded in sequence for discharge at the installation. This can only be completed if a Risk Assessment has been conducted and all tubular requirements are met.
- 8.B.1.10 Ensure thread protectors and end-caps are securely fastened.
- 8.B.1.11 Due care and attention should be taken when loading tubulars to avoid damage to slings.
- 8.B.1.12 All tubulars should be correctly orientated on the trailers and when loading on vessels.
- 8.B.1.13 All back-loaded tubulars should be cleaned or capped to prevent spillage of any contaminant.
- 8.B.1.14 When shipping loose protectors, it is recommended that they be placed in compactor bags or equivalent before placing in CCU. Care must be given to ensure that the compactor bag's SWL is not exceeded.

## **8.B.2 Bundled Tubulars**

- 8.B.2.1 Certified transportation frames are considered best practice for smaller dimension tubulars.
- 8.B.2.2 Only tubulars of the same diameter should be bundled together and whenever possible should be of similar length.
- 8.B.2.3 The number of tubulars in each bundle should be such that the inside/middle tubulars are gripped and will not slip out of the bundle. Whenever practicable tubulars over 5.5" in diameter should be bundled in 'odd' numbers.

## **8.B.3 Individually Slung Tubulars**

- 8.B.3.1 Prior to loading individual tubular cargo, bedding rope must be placed at appropriate positions on the vessels intended loading area. The minimum of two certified securing arrangements must be placed at equal distance approximately 25% from the ends of the intended stow. The length and/or height of securing arrangements must be sufficient to ensure that the entire tubular stow is secured.

Examples of certified securing arrangements are: lashing chain, webbing, wire, pipe pins/stanchions, stretchers, ratchets, shackles, etc.

- 8.B.3.2 Specifically for vessel loading, only tubulars of the same diameter are to be stowed together and wherever possible should be of similar length to ensure the tubulars are properly secured and positioned between the securing arrangements.
- 8.B.3.3 Smaller individual joints or pup joints that cannot be stowed between securing arrangements and are considered to be less than 60% overall length of average joint, must be secured as a separate item or shipped in cargo baskets.

## **8.B.4 Access and Egress**

During loading and unloading of bundled tubulars on a vessel, consideration must be given to the Load Handlers and specifically safe means of access and egress to the bundle.

Samson posts should always be put into deck slots where tubing / drill pipe is bundled. The use of Samson posts is considered good practice in the event that the installation only takes 'part' of the load. This also ensures that bundles are kept in "small parcels".

Tag lines and industry approved 'hooks' for retrieving slings should be used wherever possible preventing Working at Height, reducing the potential of a fall.



Personnel should never attempt a lift from a bundle of tubulars whilst standing on surrounding tubulars.

Employers must also ensure that suitable PPE is donned paying particular attention to anti-slip footwear.

## **8.B.5 Examples of Drilling Tubulars**

1. Tubing Frame
2. Tubing Bundle
3. Tubing – small frame
4. Tubular Packing System

## 8.B.5.1 Illustrations of Drilling Tubulars

No	Description	Illustration
1	<p>Tubing Frame Restraining bars to be securely fastened to avoid pipe slipping.</p>	
2	<p>Tubing Bundle Care should be exercised on removing slings due to stowage movement.</p>	
3	<p>Tubing – small frame Secure method of maximising storage and transportation of tubing.</p>	
4	<p>Tubular Packing System</p>	

## APPENDIX 8.C – SPECIAL CARGO

### 8.C.1 General

All cargo in this category must be considered as non-routine and the lifting operations planned as in Section 8, Lifting and Slings.

It is strongly recommended that, when planning the shipment of special cargo, logistics personnel are involved at the earliest opportunity.

### 8.C.2 Unusual Shape and Weight Distribution

#### 8.C.2.1 Assessment of unusual cargo

Considerations which must be taken into account when assessing unusual items of cargo are as follows:

- i. Items with high and/or offset centre of gravity will be unstable.
- ii. Whether any additional securing arrangements are required.
- iii. Cargo may be shipped or lifted in horizontal position for later up-ending offshore. In these circumstances all aspects of transportation, lifting and installation operations to be subject to a full Risk Assessment being carried out.
- iv. Cargo may require use of lifting beams or frames or asymmetric rigging arrangements.
- v. During road transportation beams or frames must be removed and stowed as separate cargo items. Where removed and subsequently re-attached for the lifting operations a full Risk Assessment should be performed. Otherwise they must be secured in a suitable manner to prevent damage.
- vi. Long cargo baskets should lift horizontally.

#### 8.C.2.2 Unusually Heavy Items (>20 tonnes)

- i. May require stowage in particular part of vessel's deck.
- ii. Should involve discussion between all parties, including vessel Master.
- iii. Must involve assessment of lifting dynamics.
- iv. May involve further reduction in environmental criteria for operation.

#### 8.C.2.3 Unusually Long, Fragile Items

- i. May require use of special packing arrangements.
- ii. May require the use of tag lines. If it is considered necessary it should only be done after a Risk Assessment has been undertaken, see Appendix 8.D.
- iii. Items vulnerable to water damage must be suitably protected.

#### 8.C.2.4 Internal Sea Fastenings in CCUs

Internal Sea Fastening in CCUs involving welding must only be undertaken following engineering review and consultation with the Operator and container fabricator/owner.

#### 8.C.2.5 Lift Integrity

Ensure that all securing bolts and fastenings are present and tightened up appropriately.

#### 8.C.2.6 Fragile Items, Pre-assembled and Pre-commissioned Machinery Items Requiring to be Kept Dry

Because of the fragile nature and the high value of these items, they should be transported in a specially designed lifting frame/module. If not, the following points should be considered:

- i. These items should be crated in a heavy-duty material to reduce the potential for damage.
- ii. The crate should also be made adequately to be able to be lifted from a CCU.
- iii. The crate should come complete with its own lifting arrangements.
- iv. The crate should be labelled to clearly identify the fragile nature of the goods.
- v. The crate should be loaded into a container ensuring due consideration has been taken for removal when it reaches its final destination. The item should then be secured in the container as detailed within these guidelines.
- vi. Consideration should be given to items requiring to be kept dry.
- vii. Refer to the British Standard for crates: BS1133-8: 1991.

#### **8.C.2.7 Special Lifts to Normally Unattended Installations (NUIs)**

Some NUIs have crane weight restrictions, which mean that placing even the smallest of equipment in a CCU will lead to the SWL of the crane being exceeded.

Where such crane weight restrictions apply, operations must be Risk Assessed, with the following points being considered:

- i. It may be safer to use fibre slings or suitably coated wire rope slings to lift equipment or place equipment inside and remove equipment from CCUs.
- ii. In the case of scaffolding, if it cannot be loaded into a half height container due to crane weight restrictions then it should be pre-slung and secured using steel banding or other suitable alternatives around the bundle to prevent movement.

#### **8.C.3 Back-loading of Bulk Underdeck Cargo to Support Vessel Tanks**

Vessels supplying the offshore industry are required to carry a variety of bulk liquids in dedicated tanks within the ship to supply installations offshore. It has been noted on a number of occasions that bulk liquids back-loaded to ships have been incorrectly declared by offshore installations and drilling rigs. These products can have the potential to seriously impact the technical integrity of the vessel.

For specific bulk backload procedures refer to Oil & Gas UK Offshore Support Vessel Guidelines. Particular attention is drawn to MGN 283 (M).





#### **8.C.4 Bulk Transfer to/from Portable Tanks**

When offshore support vessels are required to carry portable tanks that are to be loaded or discharged whilst on board, the suggested template as per MCA Disc/Circ 12, Annex 3 "Procedures for the discharge and loading of dangerous goods from portable tanks carried on the deck of offshore supply/support vessels" should be completed and submitted to the local MCA's Marine office prior to loading the tanks to gain approval. Particular attention is drawn to MGN 282 (M).

#### **8.C.5 Examples of Special Cargo**

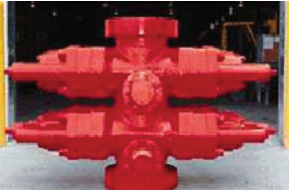
1. Anchors
2. Blow out Preventer (BOP)
3. Lifeboat in Transportation Frame
4. Fishing Friendly Frame
5. Subsea Christmas tree

## 8.C.5.1 Illustrations of Special Cargo

No	Description	Illustration
1	Rig Anchors	 Three yellow, L-shaped rig anchors of varying sizes are shown against a plain background. They are designed for securing heavy equipment on a rig deck.
2	Blow Out Preventer Frames are the preferred means of transportation	 A large, complex, red-painted metal frame for a Blow Out Preventer (BOP). It has a central vertical section with several horizontal arms extending outwards, forming a cross-like shape.
3	Lifeboat in Transportation Frame	 A yellow lifeboat is shown mounted on a yellow metal transportation frame. The frame is designed to support the lifeboat and facilitate its movement on a ship's deck.
4	Fishing Friendly	 A yellow metal frame designed for fishing operations. It features a large, open, triangular structure with a mesh or grate bottom, likely used to catch fish while allowing water to pass through.
5	Subsea Christmas Tree	 A subsea Christmas tree is being transported on a deck. The tree is a large, complex structure with multiple levels and is supported by yellow slings and a yellow frame. It is being moved along a wooden deck towards a building.

## Appendix 8.D – Use of tag lines

### 8.D.1 Introduction

In certain circumstances light, soft lines may be used to assist in the handling of long and/or fragile items of cargo. These are often referred to as tag lines.

It must be recognised that, whilst such aids may assist operations, their use does introduce some additional risks, as described below.

### 8.D.2 Risks

Additional risks associated with the use of tag lines include the following:

- i. Potential injuries from dropped objects as a result of personnel handling cargo having to work in closer proximity to suspended loads than would normally be the case.
- ii. Potential injuries, resulting from personnel handling cargo being dragged across the handling area, through a heavy load rotating in an uncontrolled manner and the tag line being fouled in limbs or clothing.
- iii. Potential injuries resulting from tag lines being secured to adjacent fixed structures parting and whipping back as a result of a heavy load rotating in an uncontrolled manner.

### 8.D.3 Mitigation of Risks

#### 8.D.3.1 Make-up of Lines

Make-up of lines includes the following:

- i. Tag lines must be made up from single, continuous lengths of rope.
- ii. Apart from the knot attaching the line to the cargo, there must be no other joints or knots in the line.
- iii. Tag lines must be of sufficient length to allow personnel handling cargo to work in a safe position well clear of the immediate vicinity of the load. In this regard it is recommended that the length of the line should be not less than one and a half (1.5) times the maximum height above the handling area at which the arrangements will be used.

#### 8.D.3.2 In Use

Whilst in use, precautions should be observed as follows:

- i. Tag lines are an aid to positioning the load when landing, and as such must only be used when weather conditions would permit the lifting of the item without the use of such arrangements. It must not be assumed that, in conditions more severe than this, the use of tag lines will allow the operation to be completed safely.

- ii. At all times personnel handling tag lines must work at a horizontal distance from the load equivalent to its height above the handling area, maintaining an angle between the line and the horizontal of not more than 45°.
- iii. All sections of the line, including slack, must be kept in front of the body, between the handler and the load.
- iv. Where two or more persons are handling the same line, ALL must work on the same side of the line. Any slack must be kept in front of the group.
- v. Tag lines must be held in such a manner that they can be quickly and totally released. They must not be looped around wrists, or other parts of the body.
- vi. Particular care must be taken when using tag lines whilst wearing gloves to ensure that the line does not foul the glove.
- vii. Tag lines must not be secured or attached in any manner to adjacent structures or equipment. This includes the practice of making a “round turn” on stanchions or similar structures and surging the line to control the load.
- viii. Where pre-installed lines are used, consideration should be given to providing personnel with boathooks or similar equipment to retrieve the lines without having to approach the dangerous area in the vicinity of the suspended load. An example of such circumstances would be when lines are attached to a load on the deck of a vessel, the load being then transferred to an offshore installation.

“

Potential injuries from  
dropped objects as a result  
of personnel handling cargo  
having to work in closer  
proximity to suspended  
loads than would normally  
be the case.

Appendix 8.D – Use of tag lines

”

## APPENDIX 8.E – ABNORMAL OR WIDE LOAD MATRIX

Typical Example: Abnormal or Wide Loads are subject to the local restrictions

Abnormal Load Chart				Grampian Police		NOTIFICATIONS Escortable Loads: 2 Days Non-Escortable Loads: 2 Days	
Abnormal Load Chart				Relevant Information			
Dimensions Exceeding (Metric) Width (Imperial)	Notify Police	2nd Man	Days Notice	Self Escort			
2.9	Yes	No	2	No			
3.5	Yes	Yes	2	No			
4.00	Yes	Yes	2	Yes	Self Escort required through Aberdeen City		
4.3	Yes	Yes	2	Yes	Self Escort required All Grampian, Except A90 bet Aberdeen and Tayside / A90 bet Aberdeen and Balmadie / A96 bet Aberdeen and Inverurie. (STGO) Regs apply		
4.45	Yes	Yes	2	Yes	Self Escort required also VR1 required from Transport Scotland. Movements only at week-end unless agreed otherwise		
5.00	Yes	Yes	14 days	Yes	Self Escort required, also Special Order required from Transport Scotland. Movements only at week-ends unless agreed otherwise		
6.1	Yes	Yes	6-8 wks	Yes	Self Escort required, also Special Order required from Transport Scotland. Movements only at week-ends unless agreed otherwise		
<b>Length</b>							
18.65	Yes	Yes	2	No	(C & U) Rigid length (if artic, does not include tractor unit unless over 25.9m overall) (STGO Regs. apply) Rigid & load or Semi-trailer & load (this does not include Tractor unit)		
18.75	Yes	Yes	2	No			
25.9	Yes	Yes	2	Yes	Self Escort required All Grampian, Except A90 bet Aberdeen and Tayside / A90 bet Aberdeen and Balmadie / A96 bet Aberdeen and Inverurie		
27.4	Yes	Yes	6-8 wks	Yes	(C & U Regs. apply) Special Order Required		
30.00	Yes	Yes	6-8 wks	Yes	(STGO Regs. apply) Special Order Required		
<b>Weight (Tonnes)</b>							
41 - 44	No	No		No	Hauliers <i>must</i> inform Local Road Management Units - as marked % (C&U Regs. Apply) 4 axle rigid / 5 axle artic combination - G Class Road Tax %		
>44 - 46	Yes	No	2	No	(STGO Regs. apply) Category 1 sign boards 6 axle combination %		
>46 to 50	Yes	No	2	No	(STGO Regs. apply) Category 1 sign boards - at least 6 axles %		
50 - 80#	Yes	No	2	No#	#escort only if exceptionally slow. (STGO Regs. Apply) Category 2 sign boards %		
>80# - 150*	Yes-	No	2	Yes*	+ from 80 tonnes / *escort over 100 tonnes only (STGO) Category 3 sign boards %		
150			6-8 wks	Yes	At all times. Special Order 0131-244-4363 %		
<b>Height</b>							
5.03		Yes		No	Hauliers to survey route and advise the relevant Utility Service BT - Tel: 08001694886/ Fax: 01332822808/ email: highloadroutes@openreach.co.uk Scottish and Southern Energy - See contact numbers overleaf ➤ 4.3m (14' 2") wide - 2 x self escort vehicles		

## 9.0 CARRIAGE OF GOODS BY SEA

### 9.1 Introduction

Carriage of goods by sea cargo guidance in this section outlines the principal points to be considered when preparing cargo for shipment to and from offshore locations including Interfield transfers.

A Pre-shipment Inspection shall be completed at source by a trained and competent person. The OGUUK Cargo Summary Ticket shall be completed to record the inspection and shall accompany the cargo to its ultimate destination.

The Cargo Inbound Pocket Checklist and/or the Cargo Safety and Security Tag (see 7.2, 14.1 & 14.3) shall be completed and attached to the cargo and accompany the cargo to its ultimate destination.

The documents and tags shall be completed and signed by the personnel who have performed the Pre-shipment Inspection. The purpose of signing the Tag is to denote acceptance and responsibility for the completed checks.

### 9.2 Responsibilities for Cargo Checks within the Supply Chain

#### 9.2.1 Packing

Management at each site shall nominate a Load Checker(s). The Load Checker's responsibility will be to perform a visual inspection of the cargo carrying units (CCUs) and lifting gear. It is also to ensure that the contents are packed and secured properly. The checks should be conducted prior to the CCU being loaded onto transport.

In the event that a load has not been properly packed, the load checker shall reject it and initiate remedial action.

#### 9.2.2 Vendors

Prior to cargo being transported from the vendor's premises to the Shore Base for shipment offshore, the vendor/supplier shall ensure that a person or persons are nominated to act as a Load Checker(s). Their responsibility is to ensure that all cargo is inspected to ensure that it is packaged properly and is safe and secure for transportation by road and sea. Once the vendor is satisfied that the cargo is packaged properly and safe and secure for shipment, the Load Checker shall attach a tie-wrap and yellow label to the load and sign and date it. The Load Checker shall also ensure that a Cargo Summary Tickets (see 14.4 to 14.5) completed in accordance with the Oil & Gas UK Best Practice for 'The Safe Packing and Handling of Cargo To and From Offshore Installations' accompanies each load.

#### 9.2.3 Shore Base

On receipt of cargo and prior to it being transferred to the quayside for loading onto a supply vessel, the Shore Base Load Checker shall carry out a Pre-shipment Inspection of all cargo to ensure that it is secured properly, there are no visible dropped objects or snag hazards and the integrity of the CCU and Lifting Set are satisfactory.

Once the Load Checker has confirmed that the cargo is safe to be transported by road and sea, they will ensure that the vendor/supplier has attached a tie-wrap and signed yellow label to a suitable and conspicuous point on the load. Where the cargo has been prepared and packed at the Shore Base, the label shall be signed and dated by the Load Checker.

#### **9.2.4 Quayside**

Once the cargo has been loaded and is in transit from the vendor/supplier to the Shore Base there should be no occasion that should cause its security/integrity to be jeopardised. However, it is imperative that the final cargo safety and security inspection is carried out by the Shore Base /Shipper at the quayside. If cargo is deemed unfit for shipment and the cargo is rejected, then the label should be removed and form the starting point of the non-conformance investigation.

#### **9.2.5 Shipper (Offshore)**

The aforementioned procedure shall also apply for all inbound cargo prepared at the offshore site, except that a Cargo Inbound Pocket Checklist will be completed for each lift in lieu of a Cargo Summary Ticket and loads will be tagged with a signed and dated orange label and tie-wrap.

Inbound cargo destined for transportation within the shore base or onward shipping to a vendor, shall be inspected by the Shore Base Service Provider at the quayside prior to it being loaded on to the transporting vehicle to ensure that there are no potential dropped objects and that the locking mechanism is secure.

Refer to 14.5 for the particular points to be considered when preparing tanks for shipment to and from offshore.

### **9.3 General**

Without exception, all companies sending cargo offshore should ensure that:

- i. All CCUs and lifting gear used to ship materials to or from offshore installations is correctly chosen for the purpose, in terms of type, size and load carrying capacity. They should satisfy themselves that all certification is fully in date at the time of use, and has sufficient test period remaining, to avoid the CCU certification expiring when offshore – This period is normally 30 days minimum, however reference should be made to the specific operators shipping matrices.
- ii. Only CCUs which are specifically designed and compatible for stacking should be stacked. Where CCUs are to be double stacked, the procedures and arrangements to be employed must be fully risk assessed. Written permission is required from the Site Manager/OIM before double stacking CCUs.
- iii. Precautions to be observed when stacking cargo baskets are specifically addressed in the 'Design and Handling of Cargo Baskets' published by the Step Change initiative, details of which are included in the list of References.
- iv. Containers fitted only with corner castings as a means of lifting the container, should not be presented for shipment.

- v. Containers that are lifted using corner castings are in reality, ISO containers, and are designed for use in general marine transport, loading and unloading in ports and inland waterways, by means of a four-point vertical lifting device I.E. . spreader beam, they are not designed for dynamic lifts in the North Sea.
- vi. Reference should be made to MSC/Circ 860 dated 22 May 1998 ‘Approval of Offshore Containers Handled in Open Seas Guidelines MSC/Circ 860’, which can be found in the IMDG Code Supplement. It is the responsibility of the originator to ensure that their CCUs conform to these requirements.

#### **9.4 Cargo Handling and Shipping Equipment**

- 9.4.1 All CCUs and deck cargo should be presented complete with lifting sets in place.
- 9.4.2 Where the CCU contains Dangerous Goods, the contents are required to be readily accessible in the event of an emergency, therefore, padlocks should not be used. It is, recognised that certain classes of Dangerous Goods, i.e Explosives and Radioactive materials are required to be padlocked for security purposes, to prevent interference.
- 9.4.3 The use of boat-shaped skips is no longer acceptable for offshore use.
- 9.4.4 Scaffold tubes and boards must be pre-slung for dynamic loading, i.e (4 point lift) and transported in a CCU to facilitate their safe removal / unloading offshore. Scaffold clips, should be containerised.

#### **9.5 Pre-shipment Inspection Checks for Open & Closed CCU's**

- i. Pre-shipment inspection checks are critical Management teams must ensure that sufficient time, processes and adequate resources are provided to ensure that they are completed properly each and every time.
- ii. As a minimum the following checks, some of which are illustrated in 9.7 and 9.8, must be carried out:
- iii. Check condition of CCU, including operation of doors, door hinges, seals and locks, tie-down points and ensure that there are no signs of excessive corrosion or deformation.
- iv. Check all certification is fully in date, and has sufficient test period remaining to prevent the CCU certification expiring when offshore.  
Containers with less than 30 days certification will not be shipped to any offshore installation, except by written agreement with the offshore installation manager.
- v. Remove all old hazard placards and labels.
- vi. Ensure that drainage holes are clean and free of debris. The larger open top containers with blocked drainage holes can hold up to 18 tonnes of water. Similarly, it is incumbent on the user to ensure that the drainage holes are not large enough to create a dropped object risk. All contents which are small enough to fall through the drain holes should be packaged to negate this risk.
- vii. Check that the units are clean and free of debris prior to loading.
- viii. Use cargo restraining nets in all closed CCUs. Ensure that nets are the correct size and type for the CCU and that the fixing points and nets are in good condition.

- ix. Check CCU roof, forklift pockets and all ledges for potential dropped objects such as tools, dunnage, stones, etc. Pay particular attention to CCUs with offset forklift pockets. i.e Both sets of pockets must be checked for dropped objects.
- x. Always perform full visual inspection of lifting sets and fixed lifting points and ensure the lifting set is sufficiently rated.
- xi. Check the container door(s) are closed, dogs (cams/claws) at top and bottom are fully engaged and the closing mechanism secured with a form of secondary retention e.g. Padlocks, tie wraps or karabiners so that it cannot inadvertently come open during handling and transport. Full visual structural integrity checks must be performed as part of the trip examination.

## 9.6 General Checks for Specialist Equipment

Examples of specialist equipment are Compressors, ROV Cable units, Wireline Cabins, Skid mounted pumps, and other skid mounted units.

In addition to the checks listed in 9.4 above, the following checks should also be considered:

- i. Removable items are secured for shipment or removed and placed within a CCU. Nothing should be secured to the outside of a CCU.
- ii. Locking mechanisms released for operation are re-secured, as per manufacturer's instructions, for transportation.
- iii. Due consideration should be given to eliminating any snagging hazards associated with this type of equipment.
- iv. The carriage of machinery containing dangerous goods (fuel) should be in accordance with the IMDG Code and MGN 282 (M). Where relevant, a copy of the Marine Competent Authority Approval (MCAA) documentation shall accompany the shipment.

## 9.7 Packing Cargo in CCUs

In the course of offshore operations, cargo in transit and its sea fastening arrangements are subjected to dynamic forces acting in the three axis. Such forces can be the result of shock loadings during transfer operations or vessel motions particularly during bad weather.

Goods will also experience significant forces as a result of vehicle motions or rough handling during transit. Whilst being carried on moving vehicles, goods and their securing arrangements may also be subjected to exceptional loads during emergency situations.

These forces can result in violent, unexpected movements of the goods both at the time an incident occurs or when the package or CCU is subsequently opened. Goods must be adequately packed and secured against potential movement.

Further guidance can be found in the HSE guidance note Dangerous Goods in Cargo Transport Units HSG 78.

Failure to comply with these requirements could result in severe injury to personnel and damage to material which ultimately may lead to prosecution. Examples of poor packing as follows.

## Examples of Poor Packaging





9.7.1 When packing goods, metal to metal contact should be avoided, to avoid movement during transit.

9.7.2 Management arrangements must ensure that personnel who do the work are properly trained and competent. Training should cover theoretical guidance and practical application of the relevant sections of this document relative to their everyday duties.

**9.7.3 As a minimum requirement the duties of the Packer should include the following areas:**

- i. All packages must be suitable, properly labelled and in satisfactory condition
- ii. Packages must be stowed safely and properly secured in the CCU. Checks must be made on the weights of the packages to ensure a safe load distribution and to prevent the maximum permitted gross weight of the CCU being exceeded.
- iii. The CCU should be labelled with the destination label and dangerous Goods labels if applicable.
- iv. When suspended, the lift must be level in both axes, <3% of length/breadth (equivalent to 6" in 20', 18" in 50').
- v. When loading CCUs, consideration should be given to manual handling constraints and take into account any Operator/installations specific requirements, using the Cargo Shipping Matrices provided. Always load heavier cargo at the bottom of the container and lighter materials on the shelf if using a shelved container. Heavy items over 25 KG should generally be shipped in open CCUs.
- vi. Use appropriate packing between items in CCU.
- vii. Ensure CCU contents are lashed or wedged securely, to avoid movement in transit.
- viii. Use cargo restraining nets in all closed CCUs. Ensure that nets are the correct size and type for the CCU and that the fixing points and nets are in good condition.
- ix. Check the container doors are closed, dogs (cams/claws) top and bottom are fully engaged and the closing mechanism secured so that the doors cannot open during handling and transport.
- x. Ensure that no equipment is loaded above the height of an open CCU without a documented Risk Assessment. The purpose of this is to prevent snagging, damage to contents and potential dropped objects. The use of nets, tarpaulins, wooden battens or roof bars are recommended to mitigate the risk of snagging.
- xi. Nothing should be attached to the outside of a CCU as this creates a potential dropped object. Loose items should be containerised and protective packaging should be secured using a certified lashing product (refer to manufacturer's instructions for correct use of lashing product).
- xii. Take care when packing cargo into CCUs that have internal sea-fastening lugs or any other form of protrusions, as cargo may be punctured by the protrusions and/or create an environmental spillage.

xiii. Operator's requirements may vary, but it is generally accepted that sacked and drummed mud and cement chemicals do not require sea-fastening within mini containers, provided they are palletised, double shrink-wrapped, occupy most of space within the container, a secondary door net is fitted and there are no protrusions within the container which could puncture the cargo. Intermediate bulk carriers (IBCs) shall always be sea-fastened because they do not fulfil the above criteria.

For non routine cargo, written information concerning loading and any potential hazards must be made available to the receiver of the CCU. This should include photographs or drawings and details of the lashings.

#### **9.7.4 Selection of Lashing Equipment for Packing CCUs**

A pre-requisite for safe transport is a suitable CCU with appropriate tie down points. The task of load lashing is to secure the load against the effect of dynamic forces to prevent slipping, tipping or falling.

Lashing arrangements must be constructed using appropriately rated and certified materials E.G. Woven cord-lash or ratchet binding straps. Wooden dunnage or similar material should only be used after a suitable and sufficient Risk Assessment has been completed and only ever in association with certified lashing material.

Total certified capacity of the lashing arrangements should be greater than the weight of the items being secured. Lashings should be equally distributed across the item.

#### **9.7.5 Wheeled Cargo**

All wheeled cargo, irrespective of weight or dimensions, should be secured sufficiently for shipping by taking the wheels out of commission, e.g raised on timber.

#### **9.7.6 Packages**

General packing provisions are as follows:

- i. Polystyrene chip packing and hessian sacks should not be used due to environmental and safety reasons. The product should be packed using bubble wrap or brown paper.
- ii. Items weighing more than 25kg should be labelled as "HEAVY". Attention is drawn to Step Change recommendations regarding the use of coloured weight tape to identify handling risks.
- iii. All sharp and protruding objects should be removed.

## 9.7.7 Crates and Pallets

- i. Wooden crates are generally only suitable for single use shipments of new equipment or spares, wooden cases should NOT be used for repeated use e.g. for the shipping of tools or equipment that is to be returned onshore after their use.
- ii. All crates destined for offshore shipment should be constructed from sawn wooden batons, although some plywood may be suitable, particle boards such as chip board or fibre board, are not suitable for offshore shipment and should not be used in the construction of the case.
- iii. Wooden crates destined for offshore, should have their lids secured using screws and not nails, the lid should also be secured with suitable banding or have other means of secondary retention applied during transit and if storage is to be in exposed areas such as offshore, or outdoors onshore.
- iv. Refer to British Standard BS1133-8: 2011 for more information on wooden boxes, cases and crates.
- v. Refer to International Standard ISO 6780:2003 for information on pallet standards  
Minimum Requirements and Markings for Wooden Crates Shipped to an Offshore Location.

**Gross Weight:** Stencilled on the two longest sides and the top | >25kg

**Centre of Gravity:** Stencilled on the two longest sides and one end

**Slings Points:** Stencilled on the two longest sides

ONLY the fully enclosed style of wooden crates are identified as being suitable for lifting by crane.



Crates with an open framework design as shown in Fig2, are not suitable for lifting by crane and should therefore not be shipped offshore

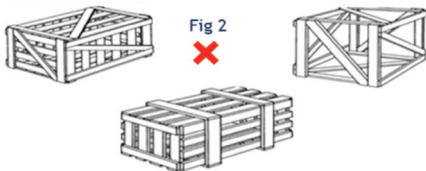

## 9.8 Closed Container – Key Points from Checklist

Ensure that the cargo restraining net is serviceable and that the method of securing it is in working condition.

## 9.9 Open Container – Key Points from Checklist

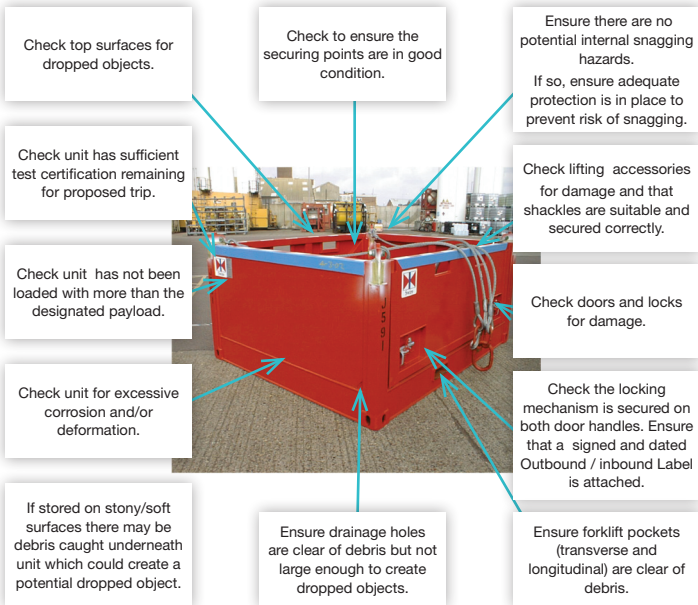

## 9.10 Snagging Hazards

Prior to shipping, the person responsible for packing CCUs must perform appropriate Risk Assessments and, if appropriate, introduce control measures to prevent snagging of lifting equipment on contents during cargo lifting operations.

Examples of control measures include:

- i. Use of the correct CCU for the job, .e.g Consider using a closed CCU rather than cargo baskets and half heights. If the item is taller than a half height or a basket, use an open top container.
- ii. Where there is a risk of lifting sets snagging the cargo, make use of suitable material to cover equipment. This could include, but is not limited to, cargo

nets, tarpaulins, wood battens, roof bars, cord-lashing and crating of equipment. The intention is to prevent the lifting gear from snagging on the equipment, so netting, tarpaulins, cord-lashing must be taut. Similarly, even empty open tops must be covered or battened to prevent the lifting gear from falling inside during transit.

- iii. Remove protruding parts from cargo in the CCU and secure in the appropriate manner.

Whilst planning stowage arrangements, Shore Base service providers in conjunction with the supply vessel crew should consider the potential for CCUs to snag on vessel structures. In particular all attempts should be made to ensure that CCU's which are narrow enough to fit into a safe haven are stowed away from the safe havens. Also, ensure that small cargo is stowed away from tall cargo as they have the potential to snag on the tall cargo when being lifted.. This requires a safe system of work to be developed which facilitates close communication between the Shore Base service provider, quayside personnel and the vessel crews.

### 9.10.1 Types of Snag Hazards

There are two distinct types of snag hazard:

1. The lift itself - e.g. CCU/Deck Cargo which has significant integral protrusions such as stacking points and pad eyes protectors which snag on other cargo or snag on the structure of the vessel itself (commonly safe havens)



2. The equipment/materials packed within a CCU in a manner which creates the potential for the lifting set to snag on it.



- i. Snag Hazards occur onshore or offshore. Onshore, CCUs can snag whilst being offloaded during crane lifting operations and from a truck using a forklift. It is incumbent on the site managers to ensure that all forklift drivers physically check the load before offloading vehicles. The purpose of this is to identify whether any CCU's have snagged on the stacking points of the adjacent container. There have been too many near misses in this area. Failure to perform these checks may result in containers snagging and toppling from the vehicle with disastrous consequences.

- ii. Offshore, the problem is exacerbated by the the sea state. The reason for this is that, as the supply vessel is alongside the installation and the lift is being performed, there is a natural rise and fall of the vessel.
- iii. The rise of the vessel leads to a relaxation in the tension of the sling set, which creates the potential for the sling set to slacken off and lower into the open CCU snagging on the material contained within.
- iv. The fall of the vessel subsequently increases the tension on the sling set. Therefore, where the sling set has snagged on the material within the CCU, the tension tightens it and an excessive amount of strain is placed both on the material and the sling.
- v. In the case of Open Top containers, the Vessels Crew and the Crane Operator are commonly unaware that the snag has occurred until its being lifted. This may be too late to rectify it and may lead to the Open Top falling over.
- vi. The snagging, combined with the dynamic forces of the lifting operation have the potential to cause something to break, usually the materials and/or the sling set.
- vii. In some cases it has been known for part of the material to snap off and become a projectile. In severe cases there is the potential for the snagged leg of the sling set to snap, putting even more pressure on the remaining three legs to conclude the lift. This forces the Crane Operator to land the now spinning CCU either back onto the ship's deck or the installation, both of which have limited space.

A broken wire rope sling leg contains stored energy which has the potential to injure / kill. Worst case scenario is that the lifting operation fails and drops the open top container from height or similarly the projectile strikes someone on deck causing serious injury or death.

## 9.10.2 Snag Hazards - Best Practice

In order to identify the risks and implement control measures which mitigate the risk, the following guidelines should be followed.

### 9.10.2.1 CCU/Deck Cargo

- i. Careful consideration should be given to the type and design of CCU/Deck Cargo used when shipping cargo offshore.
- ii. CCUs and Deck Cargo should be inspected to determine whether there is any risk of protruding parts snagging on Safe Havens or adjacent cargo. These protrusions include but are not limited to – Stacking points and Pad Eye protectors which are larger than usual, tie-down hooks, door handles, and any items which are attached to the external surfaces of the unit.
- iii. Where it is not feasible to modify the CCU or Deck Cargo and there is no suitable alternative, it should be stowed on deck well away from cargo and safe havens or anything else which it might snag on.

### 9.10.2.2 Equipment/Materials within the CCU

- i. As detailed within section 9.7.3 of this document, Equipment/Materials should not protrude above the top of an open CCU/Deck Cargo (Basket, Open Top, Skip, Fabricated structure) without specific Risk Assessment. Notwithstanding this, the potential still remains for the CCU/Deck Cargo slings to snag on contents which are lower down inside an open CCU /Deck Cargo.
- ii. Every open CCU should be risk assessed to determine whether there is the potential for the sling set to catch on the contents during the lifting operation. Where the potential has been identified, control measures must be implemented to prevent the CCU lifting set from snagging on the protruding equipment or falling inside the CCU and snagging on the contents.
- iii. Examples of suitable control measures to cover the top of the open CCU are tarpaulins and nets to cover the top of the CCU. It is vital that the tarpaulin or net used to cover the open CCU is sufficiently tensioned to prevent the weight of the sling set from falling inside the unit. Roof bars or similar braces can also be used to prevent the sling set from falling in.
- iv. The fitting of tarpaulins/nets will not only prevent snag hazards but is also intended to prevent the lifting set from falling back inside the open CCU. It is not safe for the deck crew to use a step ladder in open seas to retrieve the lifting set, so the cargo may need to be round tripped to enable the lifting set to be retrieved.

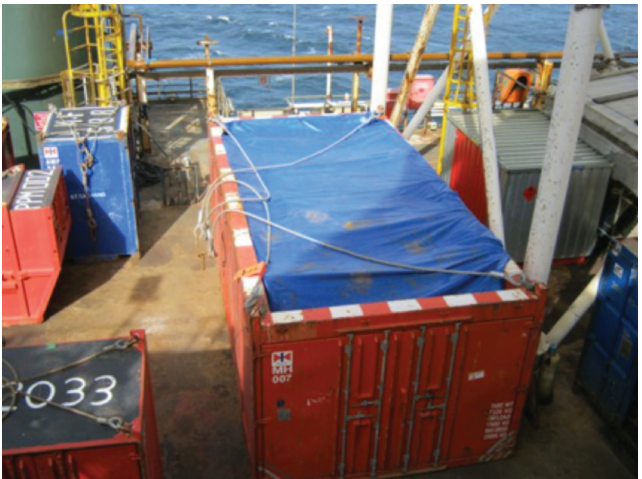

- v. Identification of snag hazards is not always apparent; therefore, to remove any subjectivity, best practice is to cover all open CCUs. Standard tarpaulins are designed to prevent water ingress and can be unwieldy and difficult to fit. They also have the negative effect of retaining water. The optimum solution is to use bespoke netting, roof bars or wooden battens.

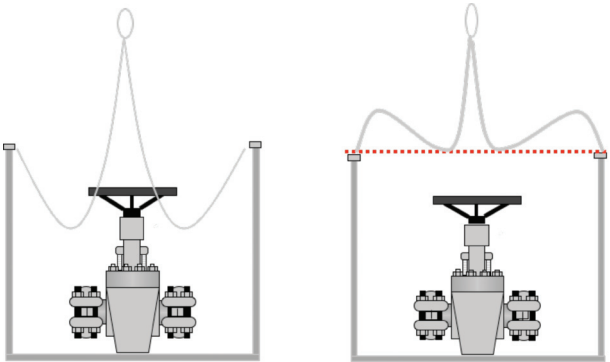

### 9.10.2.3 Responsibilities

It is the responsibility of the Packer to identify the snag hazards and implement effective control measures. The shipper has the responsibility of performing the final inspection of the cargo and approving or rejecting it for shipment.

### 9.10.2.4 Innovations

The issue of snag hazards is not unique to individual operators or indeed service providers, it is an industry problem. As such, there are many innovative solutions being developed. (See below)



Open Top Extension Frame



Tarpaulins with Bungee Cords



Top Net



Removable Roof Panels



Lidded Units



## 9.11 CCU Standards and Inspection Requirements

### 9.11.1 Construction Standards

CCUs used for the carriage and handling of cargo to and from offshore installations must conform to one of the following standards:

DNV 2.7-1 2013

This Standard for Certification applies for transport related requirements for offshore containers with respect to design, manufacture, testing, certification, marking and periodic inspection. The Standard for Certification covers the container structure and any permanent equipment for handling, filling, emptying, refrigerating, heating and safety purposes

- i. DNV 2.7-3:2011 Portable offshore units  
This Standard for Certification No 2.7-3 covers all other types of portable offshore units, other than offshore containers.
- i. BS EN 12079:2006 Parts 1, 2 and 3 Offshore containers – design, manufacture and marking, and periodic inspection, examination and testing  
This standard specifies requirements for the design, manufacture and marking of offshore containers with a maximum gross mass not exceeding 25,000kg and also gives guidance with reference to lifting sets. Part 3 deals with the periodic inspection, examination and testing.
- 1. DNV 2.7-1:2006 Offshore containers  
This certification note covers the requirements for offshore containers with respect to design, manufacture, testing and certification including the lifting sets. The DNV certifying authorities issued a 'Position Paper' in January 2007 which related to the marking and certification of sling sets
- ii. DNV 2.7-3: 2006 Portable offshore units  
This standard covers types of portable offshore units with a maximum gross mass exceeding 25,000kg but not exceeding 50,000kg.
- iii. BS EN 12079:1999 Offshore containers – design, construction, testing, inspection and marking.  
This standard specifies requirements for design, manufacture and marking of offshore containers with a maximum gross mass not exceeding 25,000kg. It also established a system for plating offshore containers linked to a define scheme for periodic examination and test and introduced a requirement for pre-trip inspection.
- iv. DNV 2.7-1:1995 Offshore containers  
This certification note covers the requirements for offshore containers with respect to design, manufacture, testing and certification including the lifting sets.
- v. DNV 2.7-1:1989 Offshore containers  
This certification note covers the requirements for offshore containers with respect to design, manufacture, testing and certification including the lifting sets.
- vi. BS 7072:1989 Inspection and repair of offshore containers  
This code gives recommendations for plating, marking, examination, testing and repair of offshore containers.

**Note:** It should be noted that BS7072 was withdrawn on 15 October 1999 and Cargo Transporting Units (CTU) constructed to BS7072 alone, may not comply fully with MSC/Circ.860, requirements. Therefore CTUs that do not fully comply with MSC/Circ.860 built to BS 7072 may continue to be used subject to them being maintained and surveyed in accordance with a recognised standard until 1 January 2015. - MGN282 (M).

Effective January 1st 2015 containers certified to BS 7072 can no longer be used for the carriage of Dangerous Goods.

All offshore containers shall be periodically inspected, examined and if necessary tested in accordance with the relevant manufacturing standard.

**Please see table below:**

Schedule of periodic inspection, examination and testing of container						
Inspection interval	Manufacturing standards inspection requirements					
	BS 7072 1989	DNV 2.7-1 1995	EN 12079 1999	DNV 2.7-1 2006	EN 12079 2006	DNV 2.7-1 2013
On manufacture	T	T or VN **	T	T or VN **	T or VN **	T or VN **
6 months	V					
12 months	VN	V	V	V	V	V
18 months	V					
24 months	T	V	V	V	V	V
48 months		V	V	VN	VN	VN
60 months		V	VN	V	V	V
** Testing as appropriate to batch or bespoke units						
After substantial repair or alteration	T	T	T	T	T	T
T	Proof load test, non-destructive examination and visual inspection					
VN	Non-destructive examination (NDE) and visual inspection					
V	Visual examination only					

### 9.11.2 Pre-use Inspections

Immediately before transporting a container offshore and before its return trip the container shall be visually inspected.

The appointed person shall check the validity of the certification by reference to the data plate and verify that the container, including its lifting set, is free from obvious defects rendering it unfit for use. It is recommended that this inspection should consist of, as a minimum, the following checks:

Pre-trip inspection check list		
	Fail	Pass
a. Check data plate demonstrates sufficient certification (see 9.12.4)	<input type="checkbox"/>	<input type="checkbox"/>
b. Check safety markings to ensure they meet the standard requirement (see 9.11.1)	<input type="checkbox"/>	<input type="checkbox"/>
c. Check lifting set for obvious signs of damage (see 8.4.4)	<input type="checkbox"/>	<input type="checkbox"/>
d. Check lifting set to establish that all parts are present, correct, properly connected and secure	<input type="checkbox"/>	<input type="checkbox"/>
e. Check container roof, forklift pockets, frames etc. for loose items	<input type="checkbox"/>	<input type="checkbox"/>
f. Check that safety nets are in position where necessary and that tie down points are in place and are fit for purpose	<input type="checkbox"/>	<input type="checkbox"/>
g. Check container doors are closed, secured and locking mechanism undamaged	<input type="checkbox"/>	<input type="checkbox"/>
h. Check drainage holes are clear on open containers but not large enough to create an opportunity for dropped objects	<input type="checkbox"/>	<input type="checkbox"/>



## 9.12 Marking

### 9.12.1 Safety Marking

All offshore containers must have the appropriate safety markings.

Although the requirements for these markings can differ slightly from standard to standard, the basics remain the same. To clearly delineate the perimeter of a container, particularly in poor lights, the tops of closed containers and the top rails of open framed containers shall be marked as follows:

- i. Closed containers shall be marked with a band of solid contrasting colour not less than 100mm wide round the roof perimeter. If the roof of the container is recessed below the top perimeter rail, at least the top surface of the top rail shall be marked.
- ii. Open and frame containers shall be marked on the top surface of the top rails, with either hatching in a contrasting colour or a solid light colour.
- iii. Where a container is fitted with fork pockets designed for handling the container only when empty (e.g. on some tanks and long baskets) then the words "Empty lift only" shall be clearly displayed near each set of fork pockets in characters not less than 50mm high.

### 9.12.2 Identification Marking

All offshore containers shall be marked with a unique identification number issued by either the fabricator or the owner. It is a requirement of manufacturing standards that the identification number is to be marked on the container as follows:

- i. The identification number shall be prominently and indelibly displayed on all sides of the container (as viewed from ground level) in characters of contrasting colour, not less than 75mm high.
- ii. If a container has a roof, the container number shall be displayed on the roof, in characters 300mm high or more. The markings should be carried out in such a way as to avoid incorrect interpretation, e.g. by underlining. Where applicable, the lower edge of the marking shall be positioned near the front of the container in which the door is located.
- iii. Each container shall have the fabricator's serial number welded on the frame in characters at least 50mm high. This is NOT a requirement of BS 7072:1989.

### 9.12.3 Information Marking

Each container shall be clearly marked with the container maximum gross weight (kg), tare weight (kg) and payload (kg). This information shall be displayed in characters of a contrasting colour no less than 50mm high. In addition if a container is carrying hazardous material the container must be marked with the relevant dangerous goods placarding.

On each CCU a matt black square of sufficient size should be provided for information markings such as destination, cargo hazards, etc.



### 9.12.5 Inspection Reports

When, in the opinion of the inspector, a container and its lifting set are suitable for service, a report to that effect will be issued. These reports should accompany the container and be available for viewing as and when required.9.13

Expiry of validity whilst Unit(s) Offshore

Owners and users of CCUs and similar equipment should ensure that precautions are taken to prevent the validity of the unit expiring whilst in use.

As discussed elsewhere in these guidelines, one such precaution may be to ensure that the validity of all CCUs have a minimum period of 30 days prior to them being shipped offshore.

Alternatively, where it is known that equipment may be retained on the installation for an extended period, it may be necessary to arrange for an offshore revalidation programme by a competent person mobilised for this purpose.

Typically, such equipment will include temporary control cabins, generators, Wire-line units etc.

However circumstances do occur when, for a variety of reasons, validity of units or equipment may be allowed to lapse.

In such circumstances, and in the event of any subsequent requirement to be returned onshore as 'controlled lifts', it is recommended that the following practices, which are dependent on the issue date of the most recent validity records be adopted.

It should be noted that in ALL circumstances where the practices recommended in this Section are adopted, the relevant units must be returned or transported onshore in an EMPTY condition, i.e. they must contain NOTHING except free air at ambient pressure.

### 9.13.1 Test Certificate(s) / Validity of units Less than 18 Months Old

Relates to equipment where the documentation / validity has expired less than one year ago.

- i. The unit or equipment, together with all lifting equipment, to be fully inspected by competent person on installation in direct charge of lifting operations using guidelines relating to "thorough examinations" as described in Appendix 13.
- ii. All damaged or defective equipment to be replaced as required.
- iii. Sea fastenings, if installed, to be removed.
- iv. Backload reports to be prepared and signed by competent person referred to above, confirming inspection and suitability of unit(s) or equipment to be lifted as required in the course of one transit from the offshore installation to eventual onshore destination. Backload reports to accompany the lift(s) to the destination.
- v. Prior to any subsequent use of the unit(s) or equipment after return, a thorough examination in a controlled environment by a competent person having access to all necessary testing facilities and in accordance with the requirements of any written scheme of examination, must be undertaken.

Following such examination appropriate validation documents shall be issued and plates re-marked as required.

### **9.13.2 Test Certificate(s) / Validity of units More than 18 and Less than 66 Months Old**

Relates to equipment where the documentation / validity has expired more than one year but less than five years ago.

- i. The unit or equipment, together with all lifting equipment to be fully inspected by a competent person, who should be mobilised to the installation and may use information in this document relating to “thorough examinations” as described in Appendix 13.
- ii. Following inspection this competent person will make any recommendations seen fit to facilitate return of the unit(s) onshore which may include:
  - All damaged or defective equipment to be replaced as required.
  - Sea fastenings, if installed, to be removed.
- iii. Prior to any subsequent use of the unit(s) or equipment after return, a thorough examination in a controlled environment by a competent person having access to all necessary testing facilities and in accordance with the requirements of any written scheme of examination, must be undertaken

Following such examination appropriate validation documents shall be issued and plates re-marked as required.

### **9.13.3 Test Certificate(s) / Validity of units More than 66 and Less than 126 Months Old**

Relates to equipment where the documentation / validity has expired more than five years but less than ten years ago.

- i. The unit or equipment, together with all lifting equipment to be fully inspected by a competent person, who should be mobilised to the installation and may use information in this document relating to “thorough examinations” as described in Appendix 13.
- ii. Following inspection this competent person will make any recommendations seen fit to facilitate return of the unit(s) onshore which may include:
  - All damaged or defective equipment to be replaced as required.
  - Sea fastenings, if installed, to be removed.

It is unlikely that any unit(s) or equipment returned onshore in this manner will be suitable for further offshore use.

However should particular circumstances require that the unit(s) or equipment are re-used, a thorough examination, in a controlled environment by a competent person having access to all necessary testing facilities and in accordance with the requirements of any written scheme of examination, must be undertaken.

Following examination appropriate validation documents shall be issued and plates re-marked as required.

#### 9.13.4 Test Certificate(s) / Validity of units More than 126 Months Old

Relates to equipment where the documentation / validity has expired more than ten years ago.

The unit or equipment, together with all lifting equipment to be fully inspected by a competent person, who should be mobilised to the installation and may use information in this document relating to “thorough examinations” as described in Appendix 13.

Following inspection this competent person will make any recommendations seen fit to facilitate disposal of the unit onshore. This may include the unit or equipment to be scrapped on site being loaded into transit container provided for the purpose of returning the scrap onshore. In such circumstances the provisions for the disposal of waste must be complied with, see Section 15.

Alternatively, and only likely in exceptional circumstances, recommendations may include:

- i. All damaged or defective equipment to be replaced as required.
- ii. Sea fastenings, if installed, to be removed.

Any unit(s) or equipment returned onshore in this manner should not be re-used offshore.

#### 9.13.5 Summary of Recommendations Relating to Out of Test Equipment

- i. In the event that the validity of a CCU or other lifting equipment on an offshore installation has expired within the past year, the items may be transported onshore and onward to a final destination as “controlled lifts” for recertification following inspection on the installation by the competent person in direct charge of lifting operations, using the guidelines for inspections included in this document and rectification of any defects found.

A backload report confirming the inspection must accompany the item to its final destination.

- ii. In the event that the certification relating to the lifting arrangements installed on a CCU or other lifting equipment to an offshore installation has expired more than one year ago, a suitably qualified competent person must be mobilised to inspect the item(s). Recommendations made by this competent person as conditions of transporting the item(s) onshore and onward to any final destination must be complied with.



A backload report confirming compliance with these recommendations must accompany the item(s) to its final destination.

### 9.14 Types of CCUs

1. Mini Container
2. Chemical Tank - can be Horizontal, Vertical or Compact
3. Chemical Transit Tank - Plastic
4. Helifuel Tank - can be Horizontal, Vertical or Compact
5. Compactor Unit
6. Compactor Bag (Bagging Compactor)
7. 20' Container
8. Gas Cylinder Rack or Carrier
9. 10' Half Height
10. Side Door Basket
11. Swarf Skip
12. Mud Cuttings Skip
13. Long Basket or Tool Carrier
14. Waste Skip or Dual Purpose CCU
15. Waste Skip - Boat Style
16. Closed Skips
17. Subsea basket

#### 9.14.1 Illustrations of CCUs

No	Description	Illustration
1	Mini Container	
2	Chemical Tank - can be Horizontal, Vertical or Compact (shown)	
3	Chemical Transit Tank - Plastic	

No	Description	Illustration
4	Helifuel Tank - can be Horizontal (shown), Vertical or Compact	
5	Compactor Unit Ensure electrical and air supplies are disconnected	
6	Compactor Bag (Bagging Compactor)	
7	20' Container	

No	Description	Illustration
8	<p>Gas Cylinder Rack or Carrier</p> <p>i. Ensure positive security of cylinders in rack by strapping in place</p> <p>ii. Small cylinders may require additional packing and/or a special container</p> <p>iii. Bottles shipped in racks without valve protection plates must be capped</p>	
9	10' Half Height	
10	Side Door Basket	
11	Swarf Skip	
12	Mud Cuttings Skip	

No	Description	Illustration
13	Long Basket or Tool Carrier	
14	Waste Skip or Dual Purpose CCU	
15	<p>Waste Skip – Boat Style</p> <p>The transportation of boat shaped skips to offshore installations is prohibited in some countries</p>	
16	Closed Skip	
17	Subsea Basket	

## 10.0 DANGEROUS GOODS BY SEA

### 10.1 General

- 10.1.1 The regulations which govern the transport of dangerous goods come from the United Nations (UN) and countries which have signed up to be a member have signed up to comply with these regulations. The rules, particularly for air and sea, are therefore well settled and applicable in all parts of the world. For road and rail, the rules, although traceable to the UN, are regional and reflect regional and individual country concerns. They are all brought into force in the UK by local statutory instruments.
- 10.1.2 The object of these rules is to ensure the safety of persons, property and the environment during transport whilst facilitating the free movement of dangerous goods. At the heart of achieving this is the adoption of the principle that compliance equals safety. No further risk assessments need or are to be made. Implementing the rules means that the transport of the dangerous goods will be safe. Other operational rules must not compete or conflict with the dangerous goods rules. For example a rule requiring three copies of the dangerous goods note or the safety data sheet would be acceptable. They do not conflict with the dangerous goods requirements. An operational rule to placard a container with 1.4S explosives inside would be in conflict as they are 'not required'.
- 10.1.3 However, as we cannot see inside the packaging and packages should not be opened, the system adopts a further principle. Judgements about compliance with the parts that we cannot see are based upon judgements about compliance with what we can see. If insufficient care has been taken to ensure compliance with what is visible then there is an assumption that what cannot be seen is possibly not compliant either. In such a case the shipment is unsafe because of this lack of external compliance even if the internal situation in fact is compliant.
- 10.1.4 For this reason if a container with dangerous goods inside has only three placards instead of four the wrong response is simply to 'replace' the fourth. If another container is placarded for both limited quantities of dangerous goods and other dangerous goods the wrong response is simply to remove the limited quantity placards. For the same reason if a transport document contains both a reference to the total quantity and a reference to the containers being 'Empty Uncleaned' the wrong response is simply to remove the irrelevant reference.
- 10.1.5 The rules place a number of obligations on the various parties to the transport especially the consignor. These are to classify, identify, pack, mark, label and document each shipment. The first obligation settles whether it is dangerous for transport or not. The second gives the dangerous goods a name. The third enables it to be packaged. The fourth, fifth and sixth obligations communicate to all third parties that the transport is safe.

- 10.1.6 Once the first two obligations have been completed the hazards (class/division) and the risks (e.g. packing group) have been identified and the goods have been named with a specific UN number and Proper Shipping Name. This enables the correct packing instruction and packaging to be selected. Unless going as limited or excepted amounts the packaging must be the correct UN approved packaging. Companies wishing to manufacture suitable packing must have obtained permission after testing and this approval is part of the marking on the package. Further, in order to be compliant the packer must use the package in the way authorised (this may specify particular conditions such as the type of tape, banding or any condition which was part of the obtaining of approval for the package). Two similar fibreboard boxes may have quite different conditions for use and closure. For cylinders, IBCs and tanks periodic inspection and certification are required to ensure continuing fitness.
- 10.1.7 The consequences of failing to comply with the rules are both civil and criminal. Wilful or reckless behaviour deemed equivalent to wilfulness may lead to prosecution. The documentation for air and sea shipments contains a clause certifying that all the applicable rules have been complied with. In the event of any failure in compliance the company authorising the signature is liable financially to recompense those who have suffered any loss due to the noncompliance. This does away with the normal negligence requirement for civil liability.
- 10.1.8 Companies which are involved in the transport of dangerous goods must ensure that any person who has a part to play in implementing these obligations receives appropriate training. All training must cover three areas: general awareness, function specific and safety elements. Some of the training must have competent authority not just industry approval for the training companies, materials, instructors and exams. Such training is to be provided before assuming the responsibility of participating in the transport of dangerous goods.
- 10.1.9 It is expected that all persons involved in the transport of dangerous goods in addition to their specific responsibilities would be able to
- Participate in maintaining the containment of all dangerous goods and be watchful of any circumstances that would be evidence of a possible failure in containment.
  - Ensure that effective segregation would be maintained.
  - Have due concern to prevent the unnecessary build-up of heat.
- Failures in compliance should be identified and appropriately reported including to the competent authorities.

## 10.2 Sea Specific

- 10.2.1 The organisation which takes the UN rules and applies them to transport of dangerous goods by sea is the International Maritime Organisation (IMO). It produces every two years the International Maritime Dangerous Goods Code (IMDG Code). In the main the rules for classifying, identifying are the same. There is more detail on the requirements for classifying as a marine pollutant. The rules for marine pollutants introduce directly the methodology adopted by the Globally Harmonised System (GHS) which will be an increasing part of both the dangerous goods rules for transport and the rules for governing the classification for the supply of hazardous materials. (These rules produce the safety data sheet).
- 10.2.2 The Maritime and Coastguard Agency (MCA) has a responsibility for monitoring compliance with the IMDG Code. Part of its response is to produce Merchant Shipping Notices (MSN) and Marine Guidance Notes (MGN). Three of the more important are the MGN 340 (M) for transport of dangerous goods in containers, MGN 283 (M) for dealing with some aspects of bulk loads and MGN 242 (M+ F) for the format and reporting of incidents involving dangerous goods including marine pollutants.
- 10.2.3 In addition to packaging such as drums, jerricans and boxes of various types, dangerous goods may sometimes be shipped in intermediate bulk containers (IBCs) and tanks. There are differences in the marking and labelling requirements.
- 10.2.4 In the main dangerous goods, packages should be marked and labelled with
- The UN number and Proper Shipping Name (with the technical name added in brackets, if appropriate)
  - The UN specification code for the type of package (unless limited or excepted quantities)
  - Orientation arrows (two on opposite sides) if a liquid
  - Labels for the hazard class/division and any subsidiary hazard
  - The environmentally hazardous substance mark if a marine pollutant
- Other marks may be required and the details are to be found in the regulations and they should be referred to for their details.
- 10.2.5 For IBCs with a capacity of more than 450L the marks and labels (apart from the UN specification code) listed above are required on two opposite sides.
- 10.2.6 For cargo transport units (including containers and portable tanks) placards (250mm x 250mm) representing the hazards should be on all four sides. There are additional requirements in respect of the UN number and Proper Shipping Name. The IMDG Code should be referred to for the details. For a single substance the UN number should be included in a white rectangle in the placard on at least two opposite sides.
- 10.2.7 If containing dangerous goods in limited quantities the container must be placarded with the limited quantities mark. However, if the container contains both a load of dangerous goods in limited quantities and also dangerous goods other than limited quantities the container must be placarded only with the placards for the non limited quantities unless this would mean no placards at all.

In this case the placards for the limited quantities must be shown. An example of this would be container carrying class 1.4S dangerous goods.

- 10.2.8 The IMDG Code has some specific rules regarding the segregation of dangerous goods. They are stricter than under ADR for road. A container might be able to arrive at the quayside but get no further till any offending dangerous goods are removed. There are tables which are used to ensure that segregation is acceptable. Two are produced here.
- 10.2.9 Sea journeys in the offshore industry the transport of dangerous goods require two documents: the dangerous goods note (sometimes called the dangerous goods declaration) and the vehicle/container packing certificate. They are generally incorporated into one document. Unlike for air which is heavily prescribed the dangerous goods note may be in any form provided that it contains all the information required by the IMDG Code and for some of the information in the order required with no other information interspersed. A specimen is offered for use. It incorporates the vehicle/packing certificate.

### **10.3 Dangerous Goods in Machinery**

- 10.3.1 For some time the MCA provided an allowance for some types of machinery (generators, compressors, etc) to be transported offshore notwithstanding that the diesel inside exceeded the 5L limit for limited quantities. The allowance meant that up to 250L could be held inside the machinery. It expired on the 1st January 2014.
- 10.3.2 It has been replaced by a new rule. All machinery (other than those for which there is an existing UN number) containing more than the limited quantities of dangerous goods of any UN number which has Special Provision 363 in the relevant column of the Dangerous Goods List (including UN1202 Diesel) can be classified under the UN number for the dangerous goods (e.g. UN 1202) and not under the generic UN 3363. Special Provision 363 should be read for its full terms. However, if the amount is not more than 450L the machinery should bear one hazard label. No dangerous goods note is required.

### **10.4 Radioactives**

- 10.4.1 The transport of radioactives is a part of the offshore industry. Sealed sources are used in a variety of operational circumstances. In addition radioactive waste is generated by the process of extraction. This contaminates pipe and other equipment as well as water and other materials
- 10.4.2 The transport of class 7 radioactive material has extra requirements. One is the need for a radiation protection plan. This consists of systematic procedures for minimising the exposure to the radioactivity and monitoring to ensure that no statutory limit is exceeded.
- 10.4.3 For sealed sources extra documentation by way of certificates (e.g. Special Form) are necessary. The package labelling and the transport document require extra information including the category of package and transport index which reflect the management of the risk associated with a radioactive shipment.
- 10.4.4 For the radioactive waste the extra information includes a requirement to calculate the total activity in a shipment and express it as a percentage of certain package limits even if it is going unpackageed.

## 10.5 Dangerous Substances in Harbour Areas Regulations 1987

Port authorities have a license granted to them by the Health and Safety executive, for the purpose of Part 1 of the Dangerous Substances in Harbour Areas regulations 1987 permitting Explosives, Radioactive materials and Methanol to be brought into and carried and handled within the harbour or harbour area.

The notification of intended entry of Explosives, Radioactive materials and Methanol into the Harbour area, Packaging, Handling, Loading and Unloading shall be the same as other Dangerous Substances except that where loading of a vessel or vehicle with these substances has been completed, the Master of the vessel or the Operator of the Vehicle, shall ensure that the vessel or vehicle is taken out of the Harbour area as soon as is reasonably practicable.

To ensure that this happens, Explosives, Radioactive materials and Methanol are to be the last load on to or the first load off of any vessel berthed within the harbour.

All Suppliers of these Dangerous Substances are required to provide Out Of Hours Contact Details for each shipment and maintain an Out Of Hours service to receive these substances back into the appropriate storage facilities 24/7.



## APPENDIX 10.A - DANGEROUS GOODS FLOWCHART – INBOUND

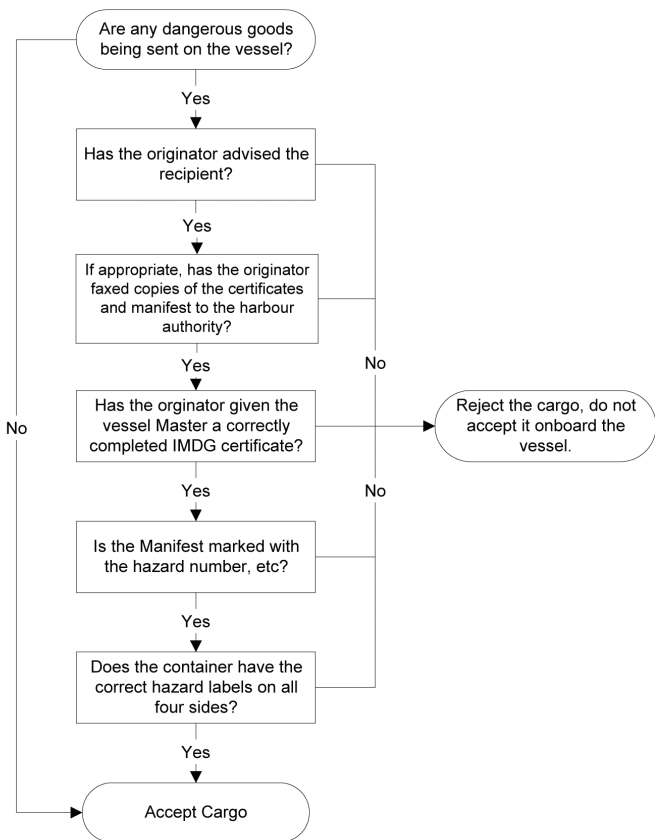

The cargo will only be accepted if all the above steps have been taken. Failure to comply with any of the above steps will result in rejection.

## Appendix 10.B - Class segregation table from IMDG Code

CLASS	1.1 1.2 1.5	1.3 1.6	1.4	2.1	2.2	2.3	3	4.1	4.2	4.3	5.1	5.2	6.1	6.2	7	8	9
Explosives 1.1.1.2.1.5	*	*	*	4	2	2	4	4	4	4	4	4	2	4	2	4	x
Explosives 1.3.1.6	*	*	*	4	2	2	4	3	3	4	4	4	2	4	2	2	x
Explosives 1.4	*	*	*	2	1	1	2	2	2	2	2	2	x	4	2	2	x
Flammable Gases 2.1	4	4	2	x	x	x	2	1	2	x	2	2	x	4	2	1	x
Non-toxic, non-flammable gases 2.2	2	2	1	x	x	x	1	x	1	x	x	1	x	2	1	x	x
Toxic gases 2.3	2	2	1	x	x	x	2	x	2	x	x	2	x	2	1	x	x
Flammable liquids 3	4	4	2	2	1	2	x	x	2	1	2	2	x	3	2	x	x
Flammable solids (including self-reactive substances and solid desensitised explosives) 4.1	4	3	2	1	x	x	x	x	1	x	1	2	x	3	2	1	x
Substances liable to spontaneous combustion 4.2	4	3	2	2	1	2	2	1	x	1	2	2	1	3	2	1	x
Substances which in contact with water emit flammable gases 4.3	4	4	2	x	x	x	1	x	1	x	2	2	x	2	2	1	x
Oxidising substances 5.1	4	4	2	2	x	x	2	1	2	2	x	2	1	3	1	2	x
Organic peroxides 5.2	4	4	2	2	1	2	2	3	3	3	x	x	1	3	2	2	x
Toxic substances 6.1	2	2	x	x	x	x	x	x	1	x	1	1	x	1	x	x	x
Infectious substances 6.2	4	4	4	4	2	2	3	3	3	3	3	3	1	x	3	3	x
Radioactive material 7	2	2	2	2	1	1	2	2	2	2	1	2	x	3	x	2	x
Corrosive substances 8	4	2	2	1	x	x	x	1	1	1	2	2	x	3	2	x	x
Miscellaneous dangerous substances and articles 9	x	x	x	x	x	x	x	x	x	x	x	x	x	x	x	x	x

The numbers and symbols in the table have the following meanings:

- 1 "Away from"
- 2 "Separated from"
- 3 "Separated by a complete compartment or hold from"
- 4 "Separated longitudinally by an intervening complete compartment or hold from"
- X Consult the dangerous goods list for any specific segregation requirements
- \* see 7.2.7.1 of the IMDG code for segregation between class 1 substances or articles

Compatibility Group	A	B	C	D	E	F	G	H	J	K	L	N	S
A	X												
B		X											X
C			X	X6	X6		X1					X4	X
D			X6	X	X6		X					X4	X
E			X6	X6	X		X					X4	X
F						X							X
G			X1	X1	X1		X						X
H								X					X
J									X				X
K										X			X
L											X2		
N			X4	X4	X4							X3	X5
S		X	X	X	X	X	X	X	X	X		X5	X

'X' indicates that goods of the corresponding compatibility groups may be stowed in the same compartment, hold, or closed cargo transport unit.

Notes:

- Explosive articles in compatibility group G (other than fireworks and those requiring special storage) may be stowed with explosive articles of compatibility groups C, D and E provided no explosive substances are transported in the same compartment or hold or closed cargo transport unit.
- A consignment of one type in compatibility group L shall only be stowed with a consignment of the same type within compatibility group L.
- Different types of articles of Division 1.6, compatibility group N, may only be transported together when it is proven that there is no additional risk of sympathetic detonation between the articles. Otherwise they shall be treated as Division 1.1.
- When articles of compatibility group N are transported with articles or substances of compatibility groups C D or E, the goods of compatibility group N shall be treated as compatibility group D.
- When articles of compatibility group N are transported together with articles and substances of compatibility group S, the entire load shall be treated as compatibility group N.
- Any combination of articles in compatibility groups C D and E shall be treated as compatibility group E. Any combination of substances in compatibility groups C and D shall be treated as the most appropriate compatibility group shown in 2.1.2.3 taking into account the predominant characteristics of the combined load. This overall classification code shall be displayed on any label or placard placed on a unit load or closed cargo transport unit as prescribed in 5.2.2.2.2.



“

The consequences of failing to comply with the rules are both civil and criminal. Wilful or reckless behaviour deemed equivalent to wilfulness may lead to prosecution. The documentation for air and sea shipments contains a clause certifying that all the applicable rules have been complied with. In the event of any failure in compliance the company authorising the signature is liable financially to recompense those who have suffered any loss due to the noncompliance. This does away with the normal negligence requirement for civil liability.

”



## **11.0 CARRIAGE OF GOODS BY AIR**

- 11.1 The primary route for the carriage of goods to and from offshore is by sea. By exception, due to operational circumstances, it may be necessary to transfer goods by air. However, due to the limitations on payload and space, prior authorisation for freight must be obtained.

Approval – permission granted by requesting company nominated person

Notification – details of approved freight submitted to aircraft operator

Acceptance – agreement received from aircraft operator to load freight

The information required to be provided by the shipper to the aircraft operator includes the following:

- i. Delivery time and date to shipper
- ii. Destination
- iii. Check-in Time
- iv. Flight Departure Time
- v. Consignee
- vi. Priority rating
- vii. Supplier
- viii. Description of goods
- ix. Dimensions and actual weight of each package

Goods which have not been pre-notified should not be loaded unless the Captain's permission has been obtained. Pre-notification is required to enable the Captain to complete flight planning and to ensure the appropriate personnel are available to handle the goods on departure/arrival. Last Minute Changes (LMCs) may be accepted at the Captain's discretion.

### **11.1 Freight Classifications**

Some offshore operators have specific airfreight priority ratings, for example:

“Vital” - this will take priority over all other freight and, if necessary, passengers.

“Priority” - this will be dispatched on the first available flight, payload and space permitting.

Shippers should check with the relevant operating company's procedures.

## 11.2 General Guidance and Freight Packaging

- i. In line with the helicopter operator procedures and Department for Transport (DfT) guidelines, all freight being shipped offshore via helicopter is required to be classified as 'known cargo' and must be accompanied by a correctly completed Cargo Security Certificate (CSC).
  - Freight can only be classified as 'known' after it has undergone either x-ray screening by x-ray trained personnel or hand-search procedures by DfT level 1 or 2 trained personnel and is securely segregated, stored and transported in line with DfT regulations.
  - The CSC declares the method of security screening that has been applied to the freight and needs to be completed by the person carrying out the security search. Cargo which is not accompanied by a valid CSC will be rejected by the helicopter operators.
- ii. All items must be "clearly, legibly and accurately" labelled not only with its contents but also with its weight.
- iii. Labelling should be durable and should remain in place for the duration of transit.
- iv. Unless specified otherwise by the Aircraft Operator, approved airfreight must be delivered to the appropriate freight shed (heliport/airport) at least one hour prior to the scheduled departure time.
- v. Dangerous Goods must be declared in accordance with the requirements stipulated in Section 12 Carriage of Dangerous Goods by Air.
- vi. Hold restrictions are enforced where freight is carried in the baggage compartment hold on all scheduled passenger flights to offshore installations.
- vii. The combined weight of the goods, i.e. baggage and freight must never exceed the maximum floor loading of the aircraft.
- viii. The maximum weight per item for personal baggage when travelling via helicopter is 11kg (25lb).
- ix. The weight limit for freight items carried in the hold should not normally exceed 25kg (55lb) per item due to manual handling considerations, but certain offshore locations may impose a lower limit. The carriage of heavier freight items in the hold shall be subject to a Manual Handling Assessment prior to loading and unloading. The exception is the S92 aircraft, which is limited to 100kg.
- x. Goods required to be loaded in the cabin, whether as a result of weight restriction or size, are subject to additional constraints such as, floor-loading, Centre of Gravity (CoG) limitations, access dimensions, etc., which would be subject to further assessment prior to loading and unloading. The decision to accept the goods should recognise any restrictions that may apply at the destination.

Some operators may restrict simultaneous carriage of passengers and cabin freight on the same aircraft.

- xi. Mechanical handling aids should be considered to reduce handling risks. Further guidance is available in Well Handled – Offshore Manual Handling Solutions HSG171.
- xii. When being transported by air, heavy items (11kg/25lb and over):
- must be adequately and appropriately packed
  - must be secure within its package with its weight distributed evenly
  - cannot move or leak
  - have appropriate means for lifting or unloading
  - must be clearly labelled “HEAVY”
- xiii. Polystyrene chips MUST NOT be used as a packing material as these can clog helicopter and installation’s engine intakes. Where found they shall be held until the originator can re-pack using appropriate material, e.g. bubble wrap, or returned for re-packing.
- xiv. Lightweight items that could be blown off the helideck when removed from the aircraft should be shipped in transit bags.
- xv. Hessian sacks are not suitable packaging for air freight and must not be used. Failure to comply with any of the above will result in rejection of goods (see Appendix 11.A UK Cargo Rejection Note – Air) with potential impact on offshore operations.

“

Due to the limitations on payload and space, prior authorisation for air freight must be obtained.

”

## APPENDIX 11.A - OIL & GAS UK CARGO REJECTION NOTE - AIR

<b>OIL &amp; GAS UK CARGO REJECTION NOTE – AIR</b>			
This form is issued in accordance with the "Oil & Gas UK Best Practice for the Safe Packing and Handling of Cargo to and from Offshore Locations".			
TO (CONSIGNOR)		CC (FREIGHT FORWARDER)	
FROM (PRINT NAME) FREIGHT SHED SUPERVISOR		FREIGHT DETAILS	
BASE		DESTINATION	
You are advised that your freight has been rejected for onward transportation to the destination noted above for the following reason(s).			
Please contact this office at your earliest convenience to arrange collection of the rejected freight/ discuss future transportation.			
<b>REASON(S) FOR REJECTION – PLEASE CHECK ALL THAT APPLY</b>			
Delivered less than one hour prior to scheduled departure time (shall be transferred to next available flight).	<input type="checkbox"/>	Warning/Orientation labels etc. are missing/ poor.	<input type="checkbox"/>
Final (full) destination not indicated on freight.	<input type="checkbox"/>	Final (full) destination not indicated on manifest.	<input type="checkbox"/>
Consignor's name not indicated on freight.	<input type="checkbox"/>	Consignor's name not indicated on manifest.	<input type="checkbox"/>
Consignee's name not indicated on freight.	<input type="checkbox"/>	Consignee's name not indicated on manifest.	<input type="checkbox"/>
Full and accurate description of freight not indicated on freight.	<input type="checkbox"/>	Full and accurate description of freight not indicated on manifest.	<input type="checkbox"/>
Weight of freight not indicated on freight.	<input type="checkbox"/>	Weight of freight not indicated on manifest.	<input type="checkbox"/>
Freight poorly packaged to endure flight safely.	<input type="checkbox"/>	Freight poorly packaged in respect of Manual Handling issues.	<input type="checkbox"/>
Total freight for this flight exceeds aircraft weight limit.	<input type="checkbox"/>	Individual weight of this piece exceeds limits set for Manual Handling.	<input type="checkbox"/>
Freight has been packed using banned materials.	<input type="checkbox"/>	Freight consists of undeclared Dangerous Goods.	<input type="checkbox"/>
Freight has not been packaged in accordance with current IATA Dangerous Goods Regulations.	<input type="checkbox"/>	Manifest has not been completed in accordance with current IATA Dangerous Goods Regulations.	<input type="checkbox"/>
Labelling is not in accordance with IATA Dangerous Goods Regulations.	<input type="checkbox"/>	Labelling is inadequate for duration of flight.	<input type="checkbox"/>
<b>FURTHER INFORMATION (INCLUDE NON CONFORMANCE CODE IF APPLICABLE)</b>			
SIGNATURE		DATE	





“  
Good or bad?  
You decide!  
”

## 12.0 DANGEROUS GOODS BY AIR

### 12.1 General

- 12.1.1 The regulations which govern the transport of dangerous goods come from the United Nations (UN) and countries which have signed up to be a member have signed up to comply with these regulations. The rules, particularly for air and sea, are therefore well settled and applicable in all parts of the world. For road and rail, the rules, although traceable to the UN, are regional and reflect regional and individual country concerns. They are all brought into force in the UK by local statutory instruments.
- 12.1.2 The object of these rules is to ensure the safety of persons, property and the environment during transport whilst facilitating their free movement. At the heart of achieving this is the adoption of the principle that compliance equals safety. No further risk assessments need or are to be made. Implementing the rules means that the transport of the dangerous goods will be safe. Other operational rules must not compete or conflict with the dangerous goods rules. For example a rule requiring three copies of the dangerous goods note or the safety data sheet would be acceptable. They do not conflict with the dangerous goods requirements. An operational rule to placard a container with 1.4S explosives inside would be in conflict as they are 'not required'.
- 12.1.3 However, as we cannot see inside the packaging and packages should not be opened, the system adopts a further principle. Judgements about compliance with the parts that we cannot see are based upon judgements about compliance with what we can see. If insufficient care has been taken to ensure compliance with what is visible then there is an assumption that what cannot be seen is possibly not compliant either. In such a case the shipment is unsafe because of this lack of external compliance even if the internal situation in fact is compliant.
- 12.1.4 For this reason if a container with dangerous goods inside has only three placards instead of four the wrong response is simply to 'replace' the fourth. If another container is placarded for both limited quantities of dangerous goods and other dangerous goods the wrong response is simply to remove the limited quantity placards. For the same reason if a transport document contains both a reference to the total quantity and a reference to the containers being 'Empty Uncleaned' the wrong response is simply to remove the irrelevant reference.
- 12.1.5 The rules place a number of obligations on the various parties to the transport especially the consignor. These are to classify, identify, pack, mark, label and document each shipment. The first obligation settles whether it is dangerous for transport or not. The second gives the dangerous goods a name. The third enables it to be packaged. The fourth, fifth and sixth obligations communicate to all third parties that the transport is safe.

- 12.1.6 Once the first two obligations have been completed the hazards (class/division) and the risks (e.g. packing group) have been identified and the goods have been named with a specific UN number and Proper Shipping Name. This enables the correct packing instruction and packaging to be selected. Unless going as limited or excepted amounts the packaging must be the correct UN approved packaging. Companies wishing to manufacture suitable packing must have obtained permission after testing and this approval is part of the marking on the package. Further, in order to be compliant the packer must use the package in the way authorised (this may specify particular conditions such as the type of tape, banding or any condition which was part of the obtaining of approval for the package). Two similar fibreboard boxes may have quite different conditions for use and closure. For cylinders, IBCs and tanks periodic inspection and certification are required to ensure continuing fitness.
- 12.1.7 The consequences of failing to comply with the rules are both civil and criminal. Wilful or reckless behaviour deemed equivalent to wilfulness may lead to prosecution. The documentation for air and sea shipments contains a clause certifying that all the applicable rules have been complied with. In the event of any failure in compliance the company authorising the signature is liable financially to recompense those who have suffered any loss due to the noncompliance. This does away with the normal negligence requirement for civil liability.
- 12.1.8 Companies which are involved in the transport of dangerous goods must ensure that any person who has a part to play in implementing these obligations receives appropriate training. All training must cover three areas: general awareness, function specific and safety elements. Some of the training must have competent authority not just industry approval for the training companies, materials, instructors and exams. Such training is to be provided before assuming the responsibility of participating in the transport of dangerous goods.
- 12.1.9 It is expected that all persons involved in the transport of dangerous goods in addition to their specific responsibilities would be able to
- Participate in maintaining the containment of all dangerous goods and be watchful of any circumstances that would be evidence of a possible failure in containment.
  - Ensure that effective segregation would be maintained.
  - Have due concern to prevent the unnecessary build-up of heat.
- Failures in compliance should be identified and appropriately reported including to the competent authorities.

## 12.2 Air Specific

- 12.2.1 The organisation which takes the UN rules and applies them to transport of dangerous goods by air is ICAO (International Civil Aviation Organisation). It produces the Technical Instructions. Implementing these has been facilitated by the trade body, IATA (International Air Transport Association) through the annual publication of its Dangerous Goods Regulations. In the UK the competent authority is the CAA (Civil Aviation Authority).
- 12.2.2 The main marks and labels which need to be found on a package going by air are
- UN number, Proper Shipping Name (supplemented with the technical name in brackets, if necessary)
  - Full name and address of the consignor and the consignee
  - Orientation arrows (2 on opposite sides) if liquid
  - UN specification code for the type of package (unless limited or excepted quantities)
  - Labels for the hazard class and any subsidiary hazard
  - Cargo Aircraft Only label (if required)
- 12.2.3 Other marks and labels may be required (e.g. for lithium batteries) and the details for placing on the packaging are to be found in the regulations and they should be referred to for their details.
- 12.2.4 At the time of presentation for air transport the consignor must be able verify that all the relevant requirements (including classifying, identifying, packing, marking, labelling and documenting) have been met. The transport document itself, called a 'Shipper's Declaration', is prescribed in minute detail down to the size, colour and content details. Two copies at least must be provided.
- 12.2.5 Normally, when a shipment is received at the airport it must be received by following strict procedures for acceptance, stowage and loading. Further documentation is required including a checklist for acceptance and a NOTOC (manifest to the captain of the aircraft).

## 12.3 Helideck

- 12.3.1 Due to the limitations on the number of people working offshore, the same person may carry out more than one function as a result of international agreement.
- 12.3.2 The CAA in the UK has increased its competent authority function in overseeing the perceived increased risk. Although the shipper and the acceptance person may be the same (e.g. store man, materials controller), the HLO and helideck crew have enhanced acceptance awareness and loading responsibilities. The Helideck Certification Agency (HCA) monitors compliance also in this area. Failure to maintain CAA/HCA compliance may lead to cessation of helicopter flights.

- 12.3.3 Prior notification of a dangerous goods shipment must be made to the helicopter operator with details of the shipment provided. This could be achieved by a copy of the proposed shipper's declaration. Acknowledgement of this does not mean acceptance. The package and documentation must be checked using the required acceptance checklist and signed on behalf of the helicopter operator. A copy of the signatory's training certificate should be attached to the signed checklist.
- 12.3.4 The packages should be looked after and 2 copies of the NOTOC prepared. NB the NOTOC is signed after the loading position is settled.
- On arrival of the helicopter the packages should be examined for any signs of damage or leakage. If any are found the packages should not be loaded.
- Once the stowage position has been agreed and consideration given to segregation the NOTOC should be completed and signed.
- All the paperwork should then be handed to the pilot. The paperwork will include: two copies of the shipper's declaration, one copy of the completed checklist and a copy of the signatory's training certificate and two copies of the signed NOTOC.
- 12.3.5 When the helicopter has departed all stations en route and the final destination must be notified of the presence on board the flight of the dangerous goods. This could be done by emailing a copy of the NOTOC to all destinations. The paperwork should be kept for a minimum of three months.

## **12.4 Radioactives**

- 12.4.1 The transport of radioactives is a part of the offshore industry. Sealed sources are used in a variety of operational circumstances. In addition radioactive waste is generated by the process of extraction. This contaminates pipe and other equipment as well as water and other materials.
- 12.4.2 The transport of class 7 radioactive material has extra requirements. One is the need for a radiation protection plan. This consists of systematic procedures for minimising the exposure to the radioactivity and monitoring to ensure that no statutory limit is exceeded.
- 12.4.3 For sealed sources extra documentation by way of certificates (e.g. Special Form) are necessary. The package labelling and the transport document require extra information including the category of package and transport index which reflect the management of the risk associated with a radioactive shipment.
- 12.4.4 For the radioactive waste the extra information includes a requirement to calculate the total activity in a shipment and express it as a percentage of certain package limits even if it is going unpackaged.

## **12.5 Samples**

- 12.5.1 When samples are being transported for further testing, there is more responsibility on the part of the consignor to ensure compliance. Such a sample must not be packed with other goods.

## APPENDIX 12.A - SHIPPER'S DECLARATION FOR DANGEROUS GOODS

Shipper		Air Waybill No		Page of Pages		Shipper's Reference Number (Optional)	
Consignee		<i>For optional use for Company logo name and address</i>					
Two completed and signed copies of this Declaration must be handed to the operator.		<p><b>WARNING</b> Failure to comply in all respects with the applicable Dangerous Goods Regulations may be in breach of the applicable law, subject to legal penalties.</p>					
<p><b>TRANSPORT DETAILS</b></p> <p>This shipment is within the limitations prescribed for: (delete non-applicable)</p> <table border="1" style="display: inline-table; margin-right: 20px;"> <tr> <td>PASSENGER AND CARGO AIRCRAFT</td> <td>CARGO AIRCRAFT ONLY</td> </tr> </table> <p>Airport of Departure:</p>							
PASSENGER AND CARGO AIRCRAFT	CARGO AIRCRAFT ONLY						
Airport of Destination:		<p>Shipment type (delete non-applicable):</p> <table border="1" style="display: inline-table; margin-right: 20px;">NON-RADIOACTIVE</table> <table border="1" style="display: inline-table;">RADIOACTIVE</table>					
<b>NATURE AND QUANTITY OF DANGEROUS GOODS</b>							
Dangerous Goods Identification							
UN or ID No	Proper Shipping Name	Class or Division (Subsidiary Risk)	Pack-ing Group	Quantity and type of packing	Packing Instructions	Authorisation	
Additional Handling Information							
<p>I hereby declare that the contents of this consignment are fully and accurately described above by the proper shipping name, and are classified, packaged, marked and labelled/placarded, and are in all respects in proper condition for transport according to applicable international and national governmental regulations. I declare that all of the applicable air transport requirements have been met.</p>				Name/Title of Signatory			
				Place and Date			
				Signature (see warning above)			

## **13.0 NON CONFORMING CARGO CODES**

### **13.1 Pre-shipment Inspection Procedures**

The purpose of this section is to standardise non-conforming cargo across the industry facilitate a common analysis of cargo, CCU and lifting set faults in order to enable identification of common identify problem areas so that they can be targeted and highlighted minimising e risk to the industry.

All non-conformances faults observed on cargo received will be coded and categorised and coded as per Appendix 9 Non Conformance Code Checklist.

Companies having their own methods of capturing these non-conformances i.e. Non Conformances Reports, Cargo Rejection Note or User Feedback Reports should, , Best Practice is to adopt a unified approach by recording non-conformances using the codes identified in Appendix 9.

It is recommended that rRandom checks of CCUs will be carried out are undertaken to establish whether they have been packed in accordance with Best Practice these guidelines. These checks should be undertaken by the operator, vendor or contractor prior to sending cargo to the Shore Base for shipment.

### **13.2 Cargo Unfit for Shipment**

On inspection, any cargo which is deemed unsafe for shipment will be quarantined and a Cargo Rejection Note (see Appendix 7) will be raised. Contact will then be made with the appropriate party to arrange rectification prior to shipment. for the fault to be rectified.

### **13.3 Non Conformance Code**

Non Conformance Codes are grouped together to identify specific items detailed within this document. There are code is broken down into the following seven sections with each category can be referenced in Appendix 9.

100 CCUs

200 Lifting and Slipping

300 Dangerous/Hazardous Goods

400 Documentation

500 Packing

600 Others

700 Positive Feedback

The faults shall be detailed on the relevant Cargo Rejection

## APPENDIX 13.A – NON CONFORMANCE CODE CHECKLIST

<b>100</b>	<b>Container Carrying Unit</b>	<b>300</b>	<b>Dangerous/Hazardous Goods</b>
101	Faulty structure, bad condition, corrosion, deformation or doors insecure.	300	Incorrect/missing labels, or old labels not removed
102	Overloaded, overweight	301	Incorrect or missing documentation
103	Out of date certification, insufficient rest period remaining	302	Incorrect, inadequate or damaged packaging
104	CCU not empty – contents unknown	<b>400</b>	<b>Documentation</b>
105	Void	400	Incorrect or missing Cargo Summary Ticket
106	Drainage holes blocked (open top)	401	Incorrect or missing Material Safety Data sheet
107	Restraining nets not in place	402	Incorrect or missing Transport Emergency Response Card (TREM Card)
108	Potential dropped objects (includes dust/powder)	403	Incorrect or missing Shipping manifest
109	Faulty door locking mechanism	404	Incorrect or missing Consignment Note
110	Loaded above desired level (open top)	405	Incorrect or missing Special/Non Special Waste consignment note
111	Liquid leaking / Spill	406	Incorrect or missing Air Transport Documentation
112	Incorrect unit for cargo	<b>500</b>	<b>Packing</b>
113	Uncontrolled/unauthorised modifications to container	501	Incorrectly or unsatisfactory Labelling (Not Dangerous Goods)
<b>200</b>	<b>Lifting and Slinging</b>	502	Incorrectly stowed and secured
200	Incorrect colour code (where applicable), unclear unique number and SWL	503	Incorrect weight distribution or excessive loading
201	Signs of wear, corrosion, abrasion and mechanical damage	504	Inadequate Packing for transportation/shipping
202	Incorrectly slung, incorrectly fitted or unapproved sling set	505	Liquid leaking from contents
203	Incorrect SWL for load being moved	506	Hazardous packing/Content
204	Incorrect shackle components ie. Pin size and type	600	Logistics, Materials and Other 700 Positive Feedback
205	Inadequate shackle pin security		
206	Incompatible materials used in shackle, pin or body components		
207	Incorrect or no Certification		
208	Trapped lifting set		
209	Twisted lifting set		
210	Incorrect/unapproved Slings		
211	Snag hazards		

## 14.0 GENERAL DOCUMENTS & FORMS

### 14.1 Oil & Gas UK Inbound Pocket Checklist - Tank

#### Oil & Gas UK Inbound Pocket Checklist - Tanks

CCU Number (Tank Specific)

.....

Cargo Checks	Yes	No
Is the tank and associated sling still within certification or complimented with a letter of acceptance to travel ashore?		
Have you checked that there are no obvious signs of damage to lift points and slings?		
Have any potential dropped objects been removed or secured? (Please check on top of tanks and inside forklift pockets)		
Is all dip and vent valves closed?		
Are all man-lids securely fastened?		
Are all caps and couplings present and secure and has a check for tampering and cross-threading been made?		
Is framework, structure, gratings, walkways and ladders in good condition?		
Are all fill / discharge valves closed including any kick rods?		
If there are hazardous goods, are there the necessary numbers of hazard labels attached on all four sides (as per IMDG code).		
If there are no hazardous goods, have all hazard labels from outward shipment been removed?		
Does the load lift horizontally in both axes? (<0.5' in 20')		
Is load over 7t? If so, attach "Heavy Lift Flag" to rigging.		
Have gross weights been checked against actual SWL?		
Has destination label been attached?		

**Name:** (please print clearly)

.....

**Company:**

.....

**Date:**     /     /

**Signed copy to be retained offshore for 3 months.**

SCHUK001 -October 2014 rev1

## 14.2 Oil & Gas UK Cargo Rejection Note - Air

### OIL & GAS UK CARGO REJECTION NOTE – AIR

This form is issued in accordance with the "Oil & Gas UK Best Practice for the Safe Packing and Handling of Cargo to and from Offshore Locations".

To (CONSIGNOR)

CC (FREIGHT FORWARDER)

FROM (PRINT NAME) FREIGHT SHED SUPERVISOR

FREIGHT DETAILS

BASE

DESTINATION

You are advised that your freight has been rejected for onward transportation to the destination noted above for the following reason(s).

Please contact this office at your earliest convenience to arrange collection of the rejected freight/discuss future transportation.

#### REASON(S) FOR REJECTION – PLEASE CHECK ALL THAT APPLY

Delivered less than one hour prior to scheduled departure time (shall be transferred to next available flight).	<input type="checkbox"/>	Warning/Orientation labels etc. are missing/poor.	<input type="checkbox"/>
Final (full) destination not indicated on freight.	<input type="checkbox"/>	Final (full) destination not indicated on manifest.	<input type="checkbox"/>
Consignor's name not indicated on freight.	<input type="checkbox"/>	Consignor's name not indicated on manifest.	<input type="checkbox"/>
Consignee's name not indicated on freight.	<input type="checkbox"/>	Consignee's name not indicated on manifest.	<input type="checkbox"/>
Full and accurate description of freight not indicated on freight.	<input type="checkbox"/>	Full and accurate description of freight not indicated on manifest.	<input type="checkbox"/>
Weight of freight not indicated on freight.	<input type="checkbox"/>	Weight of freight not indicated on manifest.	<input type="checkbox"/>
Freight poorly packaged to endure flight safely.	<input type="checkbox"/>	Freight poorly packaged in respect of Manual Handling issues.	<input type="checkbox"/>
Total freight for this flight exceeds aircraft weight limit.	<input type="checkbox"/>	Individual weight of this piece exceeds limits set for Manual Handling.	<input type="checkbox"/>
Freight has been packed using banned materials.	<input type="checkbox"/>	Freight consists of undeclared Dangerous Goods.	<input type="checkbox"/>
Freight has not been packaged in accordance with current IATA Dangerous Goods Regulations.	<input type="checkbox"/>	Manifest has not been completed in accordance with current IATA Dangerous Goods Regulations.	<input type="checkbox"/>
Labelling is not in accordance with IATA Dangerous Goods Regulations.	<input type="checkbox"/>	Labelling is inadequate for duration of flight.	<input type="checkbox"/>

FURTHER INFORMATION (INCLUDE NON CONFORMANCE CODE IF APPLICABLE)

SIGNATURE

DATE

SCHUK002 - October 2014 rev1

## Oil & Gas UK Inbound Pocket Checklist

**CCU Number (Container/Basket, etc.)**

.....

Cargo Checks	Yes	No
Have any potential dropped objects been removed or secured? (Please check on top of units, all horizontal and vertical structures including grating floors e.g. gas racks, and inside forklift pockets.)		
Are the deck lifts basket/container still within certification?		
Are all items detailed on the Consignment Note in the basket/container?		
Has all material within the basket/container been adequately secured for sea transportation?		
Are the container door locking mechanisms fully engaged?		
Have all container doors been tie wrapped?		
Is container in good condition? Any defects to be reported and appropriate action taken.		
Is the lifting bridle in good condition and shackles secure with split pins in place?		
Is load over 7t? If so, attach "Heavy Lift Flag" to rigging.		
Does the load lift horizontally in both axes? (<0.5' in 20')		
Are there any fuels, oils or potential pollutants being transported within the equipment? (Oil in reservoir or sumps, fuel in fuel tanks, etc.)		
Are there any hazardous goods in the consignment?		
If there are hazardous goods, are there the necessary numbers of hazard labels attached to the CCU.		
Have you included SEPA notes/Material Safety Data Sheets with the consignment note?		
If there are no hazardous goods, have all hazard labels from outward shipment been removed?		
Have any hired or portable equipment has been disconnected?		
Slung Lifts - Are the slings doubled wrapped and fitted with bulldogs & tywraps'		

**Name:** (please print clearly)

.....

**Company:**

.....

**Date:**     /     /

**Signed copy to be retained offshore for 3 months.**

SCHUK003 -October 2014 Rev1

## 14.4 Oil & Gas UK Cargo Summary Ticket For Outbound Cargo

**OIL AND GAS UK CARGO SUMMARY TICKET FOR OUTBOUND CARGO**  
(Use Specialist Cargo Summary Tickets for Tanks and Gas Racks)

To – OPERATIONS DEPARTMENT/BUSINESS UNIT

COLLECT FROM (SUPPLIER ADDRESS)

DATE

TELEPHONE NUMBER



Daytime:

Out of Hours:

OFFSHORE LOCATION TO BE SHIPPED TO

SAILING DATE

VESSEL NAME



ITEM No	DESCRIPTION/TYPE OF UNIT OR NO/TYPE OF JOINTS	UNIT ID OR NO OF BUNDLES	UNIT DIMENSIONS (L X W X H) (FEET)	ACTUAL WEIGHT OF LIFT	MAX GROSS WEIGHT	IMDG CLASS/ & UN No	LAST TEST DATE
1							
2							
3							
4							
5							
6							
7							
8							
9							

**CARGO CHECKLIST**

Yes/No/NA

1	Does the inspection plate show at least 30 days full remaining before statutory examination is due?	
2	Are the units free from excessive corrosion or holes?	
3	Are all drainage holes clear on open CCUs?	
4	Are all lifting sets properly fitted and configured, e.g. not twisted?	
5	Have slings been visually inspected for damage & split pins on shackles checked to see they are correctly fitted?	
6	Have you removed all potential dropped objects, e.g. Tools, debris on the lift or items strapped to lift?	
7	Has the destination label been added	
8	Are items packed and secured to prevent movement/damage in "Worst Weather" conditions?	
9	Where Dangerous Goods are being shipped, have they been pre-notified and the container correctly labelled on all four sides (Refer IMDG code)? – Chemical Tanks must have a product label attached to the tank.	
10	Is the cargo retaining net secure and positioned to prevent goods falling out?	
11	Have adequate precautions been taken to prevent Snag Hazards? (e.g., Removal or covering of hazards)	
12	Have you checked that the doors and locking mechanisms are secure, with Secondary Securing Device attached e.g. tie-wraps?	
13	Have you checked that the load lifts horizontally? (See Oil & Gas Guidelines for parameters)	
14	Have you confirmed that the Actual Gross Weight is less than or equal to Maximum Gross Weight?	
15	If Actual Weight is seven (7) tonnes or above, has a Heavy Lift pennant been attached?	
16	Have all tubulars been slung & secured correctly and checked for potential dropped objects externally and internally?	
17	Have you fulfilled the Operator's requirements if the cargo is classified as 'Hired and Portable Equipment'?	

PRINT NAME

SIGNATURE

POSITION IN COMPANY



**All checklist items must be completed prior to despatch.**

This document, which stipulates the minimum checks to be completed, must accompany goods to the ultimate destination in order to ensure the correct identification of goods. Where there are multiple truckloads, one copy is to accompany each truck with the relevant items highlighted. For hazardous cargo, a copy of the dangerous goods declaration must be faxed / emailed along with this form. **Hazardous goods arriving without notification WILL NOT be shipped. SCHUK004 -October 2014 rev1**

# 14.5 Oil & Gas UK Cargo Summary Ticket For Outbound And Inbound Tanks

## OIL & GAS UK CARGO SUMMARY TICKET FOR OUTBOUND AND INBOUND TANKS

To – OPERATIONS DEPARTMENT/BUSINESS UNIT

COLLECT FROM (SUPPLIER ADDRESS)

DATE

TELEPHONE NUMBER



Daytime:

Out of Hours:

OFFSHORE LOCATION TO BE SHIPPED TO

SAILING DATE

VESSEL NAME



ITEM NO	TANK NO	TANK SIZE	TARE & PAYLOAD	MAX GROSS WEIGHT	IMDG CLASS	UN NO	PRODUCT	LAST TEST DATE
1								
2								
3								
4								
5								
6								
7								
8								
9								

### TANK CHECKLIST

Y/N/A

1	Does the inspection plate show at least 30 days full remaining before statutory examination is due for tank vessel, frame, slings and lifting points?	
2	Where Dangerous Goods are being shipped, have they been pre-notified and the tank correctly labelled on all four sides (as per IMDG code)?	
3	Are all fill/discharge valves closed, including any kick rods?	
4	Are all dip and vent valves closed and blanking caps fitted and secured?	
5	Are all man lids securely fastened with no obvious leakage?	
6	Are all caps and couplings present and secure?	
7	Is the Tank, crash frame & roof lid free from damage and/or severe corrosion?	
8	Have you checked for and removed any Potential Dropped Objects, E.G. Tools, Debris on the tank or in the forklift pockets? (N.B. No items to be strapped to external surfaces)	
9	Have copies of all relevant certificates, dangerous goods notes, material safety data sheets and Instructions in Writing, despatched with tanks?	
10	Have you checked that there are no obvious signs of damage to pad eyes, shackles and slings and that the split pins are fitted correctly?	
11	Have the gross weights been checked to ensure that they are no greater than the SWL?	
12	Has the destination label been added?	
13	If Actual Weight is seven (7) tonnes or above, has Heavy Lift pennant been attached?	
14	Have you fulfilled the Operator's requirements if the cargo is classified as 'Hired and Portable Equipment'?	

Note: Any "NO" could result in the non-shipment of the tank.

SIGNATURE (PRINT NAME BELOW)

POSITION IN COMPANY

DATE



This document must accompany goods to the shipping port in order to ensure the correct identification of goods. Where there are multiple truckloads, one copy is to accompany each truck with the relevant items highlighted. For hazardous cargo, a copy of the dangerous goods declaration must be faxed / emailed along with this form.

**Hazardous goods arriving without notification WILL NOT be shipped.**

SCHUK005 - October 2014 rev1

## OIL &amp; GAS UK CARGO REJECTION NOTE – SEA

This form is issued in accordance with the "Oil & Gas UK Best Practice for the Safe Packing and Handling of Cargo to and from Offshore Locations".

TO (CONSIGNOR)

CC (OPERATOR)

FROM (PRINT NAME) OPERATIONS MANAGER

MATERIALS DETAILS

BASE

DESTINATION

You are advised that your freight has been rejected for onward transportation to the destination noted above for the following reason(s):

## REASON(S) FOR REJECTION – PLEASE CHECK ALL THAT APPLY

No ID, gross or tare weight on CCU.	<input type="checkbox"/>	Tie wraps/split pins missing.	<input type="checkbox"/>
CCU in poor condition.	<input type="checkbox"/>	CCU overweight.	<input type="checkbox"/>
CCU out of date/certification.	<input type="checkbox"/>	Labelling incorrect/old placards still on CCU.	<input type="checkbox"/>
Potential Dropped Object.	<input type="checkbox"/>	Container doors not sealed.	<input type="checkbox"/>
Equipment loaded over the height of the CCU.	<input type="checkbox"/>	Incorrect colour code used.	<input type="checkbox"/>
No MSDN or TREM Card with goods.	<input type="checkbox"/>	Signs of wear or damage to sling set.	<input type="checkbox"/>
Incorrectly packaged material.	<input type="checkbox"/>	Incorrect documentation.	<input type="checkbox"/>
Weight of freight not indicated on package.	<input type="checkbox"/>	Freight poorly packaged in respect of Manual Handling issues.	<input type="checkbox"/>
Freight consists of undeclared Dangerous Goods.	<input type="checkbox"/>	Freight has not been packaged in accordance with current IMDG Dangerous Goods Regulations.	<input type="checkbox"/>
Labelling is not in accordance with IMDG Dangerous Goods Regulations.	<input type="checkbox"/>	Incorrectly completed IMDG declaration.	<input type="checkbox"/>
Twisted lifting equipment.	<input type="checkbox"/>	Trapped slings and snagged equipment.	<input type="checkbox"/>
Incorrect slings used for goods.	<input type="checkbox"/>	No Certification received with goods.	<input type="checkbox"/>
Liquid leaking from CCU.	<input type="checkbox"/>	Liquid leaking from package.	<input type="checkbox"/>

FURTHER INFORMATION (INCLUDE NON CONFORMANCE CODE IF APPLICABLE)

SIGNATURE

DATE

SCHUK006 - October 2014 rev1

# 14.7 Abnormal or Wide Loads

Typical Example: Abnormal or Wide Loads are subject to the local restrictions

Abnormal Inadvisable Loads Will NOT be moved during Hours of darkness, Poor visibility, Rush-hour Traffic 0700 – 0930 & 1600 – 1830 or without Police permission.		Granangian Police		NOTIFICATIONS Escortable Loads: 2 Days Non Escortable Loads: 2 Days	
		Abnormal Load Chart		Relevant Information	
Dimensions Exceeding (Metric) Width (Imperial)	Notify Police	2nd Man	Days Notice	Self Escort	
2.9	Yes	No	2	No	
3.5	Yes	No	2	No	
4.00	Yes	Yes	2	Yes	Self Escort required through Aberdeen City
4.3	Yes	Yes	2	Yes	Self Escort required All Granangian, Except A90 bet Aberdeen and Tayside / A90 bet Aberdeen and Balnede / A96 bet Aberdeen and Inverurie (STGO) Keys apply
4.45	Yes	Yes	2	Yes	Self Escort required All Granangian
5.00	Yes	Yes	14 days	Yes	Self Escort required also VRL required from Inangport Scotland. Movements only at week-end unless agreed otherwise
6.1	Yes	Yes	6-8 wks	Yes	Self Escort and possible Police assistance required, also Special Order required from Inangport Scotland. Movements only at week-end unless agreed otherwise
Length					
18.65	Yes	Yes	2	No	(C & U) Rigid length (if artic. does not include tractor unit unless over 25.0m overall) (STGO Keys apply) Rigid & load or Semi-trailer & load (this does not include Tractor unit)
18.75	Yes	Yes	2	No	
25.9	Yes	Yes	2	Yes	Self escort required All Granangian Except A90 bet Aberdeen and Tayside / A90 bet Aberdeen and Balnede / A96 bet Aberdeen and Inverurie
27.4	Yes	Yes	6-8 wks	Yes	(C & U Regs. apply) Special Order Required
30.00	Yes	Yes	6-8 wks	Yes	(STGO Regs apply) Special Order Required
Weight (Tonnes)	All Loads weighing over 4t Tonnes - Handlers must inform Local Road Management Units - as marked %				
41-44	No	No	No	No	(C&U Regs. Apply) 4 axle rigid / 3 axle artic combination - G Class Road Tax
>44-46	Yes	No	2	No	(STGO Regs. apply) Category 1 sign boards 6 axle combination
>46 to 50	Yes	No	2	No	(STGO Regs. apply) Category 1 sign boards - at least 6 axles
50 - 80#	Yes	No	2	#	Escort only if exceptionally slow (STGO Regs Apply) Category 2 sign boards
>80# - 150#	Yes	No	2	Yes*	- from 80 tonnes / *escort over 100 tonnes only (STGO) Category 3 sign boards
150			6-8 wks	Yes	At all times: Special Order 0131:244-4363
Height					
5.03	Yes	Yes	No	No	Handlers to survey route and advise the relevant Utility Service BT - Tel: 08001094886 Tel: 01532823808 email: highloadover@openreach.co.uk Scottish and Southern Energy - See contact numbers overleaf

\* 4.3m (14' 2") wide - 2 x self escort vehicles

**NON ROUTINE OR SPECIAL CARGO ITEMS  
TRANSPORTATION TO OR FROM SITE  
BEST PRACTICE**

**PROJECT SUMMARY & CONTACT DETAILS**

---

**PROJECT SUMMARY**

<b>Project</b>		
<b>Item(s) being Transported</b>		
<b>Client</b>		
<b>Vendor or Supplier</b>		Vendor or Supplier to complete Vendor Logistics Check List (See Below)
<b>Vendor / Suppliers Agent(s)</b>		, ,
<b>Logistics Service Provider(s)</b>		, ,
<b>Shipped</b>	<b>From</b>	
	<b>To</b>	
	<b>Via</b>	, ,
<b>Further Information</b>		1.

**NON ROUTINE OR SPECIAL CARGO ITEMS  
TRANSPORTATION TO OR FROM SITE  
BEST PRACTICE**

**PROJECT SUMMARY & CONTACT DETAILS**

---

**PROJECT TEAM**

Contact Information	Particulars
Nominated Person(s)	
Representing	
Function	
Department	
Telephone, Office	
Telephone, Mobile	
Electronic Mail Address	

Contact Information	Particulars
Nominated Person(s)	
Representing	
Function	
Department	
Telephone, Office	
Telephone, Mobile	
Electronic Mail Address	

Contact Information	Particulars
Nominated Person(s)	
Representing	
Function	
Department	
Telephone, Office	
Telephone, Mobile	
Electronic Mail Address	

Contact Information	Particulars
Nominated Person(s)	
Representing	
Function	
Department	
Telephone, Office	
Telephone, Mobile	
Electronic Mail Address	

**NON ROUTINE OR SPECIAL CARGO ITEMS  
TRANSPORTATION TO OR FROM SITE  
BEST PRACTICE**

**PROJECT SUMMARY & CONTACT DETAILS**

---

**OPERATIONS SUPPORT TEAMS**

**Logistics and Quayside Operations**

Contact Information	Particulars
Nominated Person(s)	
Representing	
Function	
Department	
Telephone, Office	
Telephone, Mobile	
Electronic Mail Address	

Contact Information	Particulars
Nominated Person(s)	
Representing	
Function	
Department	
Telephone, Office	
Telephone, Mobile	
Electronic Mail Address	

**Marine Specialists**

Contact Information	Particulars
Nominated Person(s)	
Representing	
Function	
Department	
Telephone, Office	
Telephone, Mobile	
Electronic Mail Address	

Contact Information	Particulars
Nominated Person(s)	
Representing	
Function	
Department	
Telephone, Office	
Telephone, Mobile	
Electronic Mail Address	

**NON ROUTINE OR SPECIAL CARGO ITEMS  
TRANSPORTATION TO OR FROM SITE  
BEST PRACTICE**

**PROJECT SUMMARY & CONTACT DETAILS**

---

**Procurement**

Contact Information	Particulars
Nominated Person(s)	
Representing	
Function	
Department	
Telephone, Office	
Telephone, Mobile	
Electronic Mail Address	

**Operational Safety**

Contact Information	Particulars
Nominated Person(s)	
Representing	
Function	
Department	
Telephone, Office	
Telephone, Mobile	
Electronic Mail Address	

**NON ROUTINE OR SPECIAL CARGO ITEMS  
TRANSPORTATION TO OR FROM SITE  
BEST PRACTICE**

**PROJECT SUMMARY & CONTACT DETAILS**

---

**VESSELS****Vessel 1**

Contact Information	Particulars
Function	
Name of Vessel	
Name of Master (if known)	
Telephone, KU Band	
Telephone, Marisat	
Telephone, Mobile	
VHF Channels	
UHF Channels	
Electronic Mail Address	

**Vessel 2**

Contact Information	Particulars
Function	
Name of Vessel	
Name of Master (if known)	
Telephone, KU Band	
Telephone, Marisat	
Telephone, Mobile	
VHF Channels	
UHF Channels	
Electronic Mail Address	

**Vessel 3**

Contact Information	Particulars
Function	
Name of Vessel	
Name of Master (if known)	
Telephone, KU Band	
Telephone, Marisat	
Telephone, Mobile	
VHF Channels	
UHF Channels	
Electronic Mail Address	

## 14.9 Non Routine or Special Cargo Items Transportation to or from Site - Vendors Logistics Check List

### NON ROUTINE OR SPECIAL CARGO ITEMS TRANSPORTATION TO OR FROM SITE BEST PRACTICE

#### PROJECT SUMMARY & CONTACT DETAILS

#### VENDOR LOGISTICS CHECK LIST

All relevant information to be included

ORDER / CONTACT DETAILS	
Purchase Order Reference	
Logistics contact name / details	
EQUIPMENT PARTICULARS	
Equipment description	
GA Drawing provided	
Dimensions	
Weight	
Location of C of G	
Lifting Points (number, type, capacity)	
Transport Fastening Points (number, type, capacity)	
Pressurized and / or Energized parts present	
Fluids & / or Hazardous Substances present	
Electrical Power present or required	
Compressed Air present or required	
Cooling Water required	
PACKAGING AND LOADING ARRANGEMENTS	
Packaging design / type	
Dedicated Lifting Rigging supplied or offered	
Original Certificates for Lifting Rigging to accompany Cargo Item(s) throughout journey	
Plant type / capacity for handling throughout journey	
Handling recommendations throughout journey	
TRANSPORT & DELIVERY ARRANGEMENTS	
Type / capacity of Transport required	
Notifications required for road haulage, if any	
Transport risk assessment throughout journey For Ex Works all known risks to be considered	
Potential changes in C of G due to loading / movement	
ONWARD SHIPMENT	
Special precautions for loading / unloading	
Special precautions for transport by sea	
DOCUMENTATION	
Lift Plan required for movement / loading	
O&GUK Cargo Handling Guidelines to be available & consulted when planning each stage of journey	

## 15.0 WASTE MANAGEMENT

The primary legislation for waste management offshore is The Merchant Shipping (Prevention of Pollution by Sewage and Garbage from Ships) Regulations 2008 SI 2008 No 3257. The Regulation covers waste produced offshore (fixed or mobile). The OIM of every fixed manned installation or mobile rig is required to provide a garbage management plan on-board showing roles and responsibilities, waste types produced and a waste collection locator plan. The OIM is responsible to display signage forbidding waste to be thrown overboard.

All Offshore locations (fixed and mobile) are regarded as a Waste Producer. The subsequent transfer of waste to an onshore receiving facility is controlled mainly by: Special Waste Amended (Scotland) Regulations [SSI 2004/112]; Special Waste Amended (Scotland) Regulations [SSI 2005/22], Hazardous Waste (England & Wales) Regulations [SI 2005/894], Environmental Protection (Duty of Care) Regulations [SI 1991/2839]; Waste Management Regulations [SI 1996/634]. It should be noted that the waste regulated by the Scottish Environmental Protection Agency (SEPA) in Scotland and by the Environmental Agency (EA) for England and Wales require different paperwork and that the type of paperwork to be used is governed by the port of landing in the UK.

**Note:** Regulations in Scotland and England/Wales are subject to change out-with the review update of this guideline and it is the “producer’s” responsibility to ensure update awareness and compliance.

Each Offshore location is required to prepare and maintain a “Cradle to Grave” Audit Trail of all waste streams generated on the facility. The removal of waste by Supply Vessel may only take place in compliance with the Regulations. The Supply Vessel is regarded as the ‘Waste Carrier’ and for that reason should hold a Waste Carrier License for moving waste in the UK sector. The Vessel Master is responsible for receiving and discharging waste ‘cargo’ from the Supply Vessel.

The movement of waste from Offshore to final disposal site may require a number of controlled transfers - this is known as the Waste Handling Chain. Within the Waste Handling Chain, the carrier is required to hold copy of all waste transfers. Exchange of signatures on paperwork (Special/Hazardous Waste) is required to take place for each Controlled Waste Note (as issued and controlled by SEPA/EA) prior to transfer to quayside.

In accordance with UK Oil and Gas Industry, Operator Policy and UK National Waste Strategy, all waste is reported showing disposal routing with specific requirement to reduce, re-use and recycle waste where possible. All locations are required to segregate waste in order to reduce amounts sent to landfill.

The handling of waste from “Cradle to Grave” is controlled via approved licensed services only. Under the Duty of Care, all Waste Producers are required to ensure that their waste streams move and are received under such condition only. Violation of the Regulations may result in both Company and Individual prosecution by the relevant Regulatory Authority.

CCUs manifested to onshore as “empty” must physically be empty. Any contents must be manifested, regardless of the apparent insignificance, e.g. pallets, wood, rope, bags, paper, cardboard, packaging. Any hazardous or unidentifiable waste not manifested will be the subject on an investigation.

If at all possible, shipping waste materials in the same container as non-waste materials should be avoided.

## 15.1 Controlling Waste Offshore

It is the responsibility of the OIM to ensure that all waste is kept and transferred in a safe and compliant manner. All personnel (including service company personnel and visitors) must follow the Installation Waste Control Policy/ Procedures.

Comprehensive guidance is found in Appendix 6 – Offshore Waste Control Pack example. (This covers packaging options and methods of preparing paperwork for safe and compliant transfer).

## 15.2 Special Waste (Hazardous/Harmful)

The preparation of a Special/Hazardous Waste Consignment Note is normally undertaken by the person who prepares the backload manifest. The person preparing the manifest is also responsible for completing the Dangerous Goods (DG) declarations. It is most important that any declared Special/Hazardous Waste is packaged in accordance with applicable Dangerous Goods by Sea Classification code. All waste streams now have an applicable European Waste Catalogue (EWC) code which must appear (as relevant) on waste transfer notes. In addition, normal DG notifications must take place with relevant DG stickers in place as appropriate.

## 15.3 Recyclable Waste

In general, it is necessary for Offshore Operators to segregate recyclable waste streams. Typical recyclable waste is shown as:

- i. Paper
- ii. Cardboard
- iii. Timber
- iv. Drums (metal/plastic)
- v. Scrap Metals
- vi. Cable
- vii. Plastics (wrapping/bottles)
- viii. Fluorescent Tubes
- ix. Batteries
- x. Solvents
- xi. Drink Cans
- xii. Toner Cartridges
- xiii. Ink Cartridges
- xiv. Electronic equipment
- xv. Circuit boards
- xvi. Paint tins/paint/brushes, etc.
- xvii. Oily solids
- xviii. Oils / Fuels

Collections are encouraged using clear plastic bags (where appropriate) to assist with easy identification and hazard spotting for handlers. The use of black sacks is not acceptable practice.

It has become normal practice for the waste service provider to establish a help-line for support and assistance on any waste issues to reduce risk, be it technical/administrative.

## User Guide

The following guidelines are for reference by material controllers/persons responsible for preparing manifests for back load.

1. A waste catalogue/reference list is provided to identify type/terminology as standard supply.
  - a) Please package waste in accordance with Oil & Gas cargo transfer guidelines/IMDG classification.
  - b) Use the waste reference lists to identify waste type and follow the preparation guidelines for special and non-special waste consignment note completion.
2. Use the step-by-step instructions to complete the necessary paperwork.
3. If further assistance is required please phone your Enviroco Waste helpline/EBA on (01224) 884669 (Aberdeen) or (01779) 485200 (Peterhead) for advice on sourcing paperwork, completing paperwork, choosing packaging, advice on unknown wastes and your legal requirements.

Waste offshore is controlled under 'Control of Pollution (by Garbage) at Sea Regulations' and regulated by the Maritime Coastguard Agency.

Once waste cargo is discharged quayside, the regulator is SEPA (Scottish Environmental Protection Agency).

UK Waste Regulations and 'Duty of Care' apply throughout the handling chain.

# Special Waste Regulations

Some wastes are harmful to human health or to the environment, either immediately or over an extended period of time. These are called special wastes in Scotland. If your business produces special (or indeed non-special) waste you have a legal obligation to make sure it's disposed of legally.

Your waste will fall into one of the following categories:

- Waste considered to be special under the Special Waste Regulations - for example, lead acid batteries or fluorescent tubes.
- Waste that is not considered to be special waste - for example, uncontaminated paper or scrap metal.
- Waste that needs to be assessed to find out whether it is special waste or not.

Enviroco have produced a waste reference list for both special and non-special waste. This gives you all the details you should need to complete both a consignment note for special waste and a duty of care note for non-special waste, the waste reference lists are available from the helpline or website.

## The Special Waste Consignment Note

For offshore waste consigned through Scottish ports you should only use the Enviroco provided special waste consignment notes when consigned to an Enviroco facility.

For consignments to other facilities (e.g. mud cuttings) you should use the Consignment Note as provided by the Drill Cuttings Processor.

## How to complete the Enviroco Special Waste Consignment Note (Scotland)

The note is split into 6 Parts; YOU are only required to complete 3 Parts! (as highlighted in yellow below)

	Part	Who Completes?
A	Consignment Details	Producer
B	Description of Waste	Producer
C	Carrier's Certificate	Carrier – Onshore
D1	Consignor's Certificate	Producer
D2	Ship's Master Certificate	Ship's Master
E	Consignee's Certificate	Disposal Site – Enviroco

SPECIAL WASTE REGULATION 1996		SPECIAL CONSIGNMENT	
No of parcels (if different) _____		NOTE NR. SC <b>50222233</b>	
<b>A. CONSIGNMENT DETAILS</b>		Please tick if you are a transfer station <input type="checkbox"/> Short _____ of _____	
1. The waste described below is to be removed from (name, address & postcode) (operator company & offshore unit)		Supply Vessel: Manifest No: _____	
2. The waste will be taken to (name, address & postcode) Environco Limited, Hibbles Waste Transfer Station, Goodbank Crescent, East Turis, Aberdeen AB12 3BQ			
3. The consignment(s) will be: one single <input type="checkbox"/> a succession <input type="checkbox"/> carrier's round <input type="checkbox"/> other <input checked="" type="checkbox"/> please specify			
4. Expected removal date of first consignment: _____		last consignment: _____ Oil & Gas Exploration & Production	
5. Name: _____ Signature: _____ Date: _____ 20 _____		On behalf of (company, address & postcode/transfer company & offshore unit)	
6. Tel: _____		7. The waste producer was (if different from 1.) (name, address & postcode) Offshore Location: _____	
<b>B. DESCRIPTION OF THE WASTE</b> No. of additional sheets <input type="checkbox"/>			
1. The waste is _____		2. The EWC* six digit code(s) assigned to the waste is: _____	
3. Physical form: Liquid <input type="checkbox"/> Powder <input type="checkbox"/> Sludge <input type="checkbox"/> Solids <input type="checkbox"/> Mixed <input type="checkbox"/>		4. Colour: _____	
5. Total quantity for removal (include units kg/tons/tonnes etc.) _____		Container size, type & number _____	
6. The chemical/biological components that make the waste special are:			
Component	Concentration (% or mg/kg)	Component	Concentration (% or mg/kg)
7. The hazard codes (e.g. H7) are: _____			
8. The process giving rise to the waste is: <u>Offshore Oil &amp; Gas Exploration &amp; Production</u>			
<b>C. CARRIER'S CERTIFICATE</b>			
I certify that today I collected the consignment and that the details in A1, A2 and B1 are correct. The quantity collected is _____ tons/tons.			
Name: _____		On behalf of (company, address & postcode)	
Signature: _____		Date: _____ at _____ hours	
3. Carrier registration No./reason for exemption: _____		2. Vehicle registration No (or mode of transport, if not road) _____	
<b>D1. CONSIGNOR'S CERTIFICATE</b>		<b>D2. SHIP'S MASTER CERTIFICATE</b>	
I certify that the information in B and C above is correct, that the carrier is registered or exempt and was advised of the appropriate precautionary measures.		I certify that I received this waste on _____ at _____ hrs.	
Name: _____		The quantity of waste received in this consignment was _____	
Signature: _____ Date: _____		The waste was landed at: _____ on _____	
On behalf of (company, address & postcode)		Name: _____ Signature: _____	
_____		On behalf of (CO) _____ Date: _____	
<b>E. CONSIGNEE'S CERTIFICATE</b>			
1. I received this waste on _____ at _____ hrs.		2. Quantity received (include units kg/tons/tonnes etc.) _____	
3. Vehicle registration No. _____		4. Waste Management Operation(s): <u>Transfer/Transfer Station</u>	
I certify that waste management licence/authorisation/exemption No. _____ authorises the management of waste described in B			
Name: _____		On behalf of (company, address & postcode)	
Signature: _____		Environco Limited Hibbles Waste Transfer Station Goodbank Crescent East Turis, Aberdeen AB12 3BQ	
Date: _____			
<b>PLEASE COMPLETE IN BLOCK CAPITALS</b>			
* The European Waste Catalogue (EWC) sets out a list of wastes pursuant to Article 1(a) of the Waste Directive and Article 1(c) of the Hazardous Waste Directive and is set out in Commission Decision 2000/532/EC (OJ No. L 194, 25.7.2000, p. 39), as amended.			
			REP. ENVY 400

Figure 1 – The Special Waste Consignment Note

## Part A – Consignment Details

SPECIAL WASTE REGULATION 1996		SPECIAL CONSIGNMENT	
No of notices (if different)		NOTE NO: <b>sc50222233</b>	
<b>A. CONSIGNMENT DETAILS</b>		Please tick if you are a transfer station <input type="checkbox"/> Sheet _____ of _____	
1. The waste described below is to be removed from (name, address & postcode) (operator company & offshore unit)		Supply Vessel: Manifest No: _____	
2. The waste will be taken to (name, address & postcode) Envirosco Limited, Hilbery Drive Transfer Station, Goodhead Crescent, East Tullis, Aberdeen AB12 3BQ			
3. The consignment(s) will be: one single <input type="checkbox"/> a succession <input type="checkbox"/> carrier's removal <input type="checkbox"/>		other <input checked="" type="checkbox"/> please specify Oil & Gas Exploration & Production	
4. Expected removal date of first consignment:		last consignment:	
5. Name: _____ Signature: _____ Date: _____		On behalf of (company, address & postcode/operator company & offshore unit):	
6. Tel: _____		7. The waste producer was (if different from 1) (name, address & postcode) Offshore Location: _____	

Figure 2 – Part A of a Special Waste Consignment Note

## Part A – Consignment Completion Requirement

Each SWCN has a unique number consigned to it by SEPA. Enter the offshore tracking details (i.e. your location, the supply vessel used and relevant manifest number for the shipment). PLEASE USE CAPITAL LETTERS.

1. You **MUST** enter the asset name and the Field Operator's full UK address in here including postcode.
2. The Envirosco Waste Reception Facility address is pre-printed on the form. If not, please check the correct Transfer Station address to enter here.
3. The consignment will be marked –  other – and is pre-printed.
4. N/A
5. Add YOUR name / signature and date. NOTE: If the field operators address is added in full (item A1) there is no need to duplicate the address.
6. Please add offshore asset phone number.
7. Add asset name as 'Producer' if not shown in item A1 above.

## Part B – Description of the Waste

B. DESCRIPTION OF THE WASTE		No. of additional sheets	The PMS* site (high content assigned to the waste is)	
1. The waste is: <u>OILY WASTE</u>		<input type="checkbox"/>	APAL	
3. Physical form: Liquid <input type="checkbox"/> Powder <input type="checkbox"/> Sludge <input type="checkbox"/> Solids <input type="checkbox"/> Mixed <input checked="" type="checkbox"/>		4. Colour: <u>VARIED</u>		
5. Total quantity for removal (include units kg/ltr/tonnas etc.) <b>ESTIMATE WASTE WEIGHT ONLY</b>		Container size, type & number <u>SKIP 1234 + AMB 205</u>		
6. The chemical/biological components that make the waste special are:				
Component	Concentration (% or mg/kg)	Component	Concentration (% or mg/kg)	
APAL				
7. The hazard codes (e.g. H7) are: _____				
8. The process giving rise to the waste is: <u>Offshore Oil &amp; Gas Exploration &amp; Production</u>				

Figure 3 – Part B of a Special Waste Consignment Note

1. List waste type (e.g. oily waste). Or if multiple items state APAL (as per attached list).

2. State APAL (as per attached list).

3. Tick the MIXED box.

4. Colour: add - VARIED.

5. Give approximate total weight of waste types. And container I.D. numbers.  
NOTE: It is important to list CCU numbers carrying special waste.

6. This section can show APAL (as per attached list) when attaching information extracted from the Special Waste Reference List as an attachment.

Once completed, remove the top white copy of the consignment note and keep a copy of the waste reference list. Hand the rest of the consignment note and waste reference list to the Ship's Master. Ensure that for every colour copy of the consignment note handed to the Ship's Master, the same number of copies of the attached list are also present.

There is no need to receive the Ship's Masters signature on your copy held on board (Rig/Platform etc).

## Part D1 – Consignor's Certificate

<p><b>D1. CONSIGNOR'S CERTIFICATE</b></p> <p>I certify that the information in B and C above is correct, that the carrier is registered or exempt and was advised of the appropriate precautionary measures.</p> <p>Name: _____</p> <p>Signature: _____ Date: _____</p> <p>On behalf of (company, address &amp; postcode) As per A1 above _____</p>
---

Figure 4 – Part D1 of a Special Waste Consignment Note

Completed by the producer detailing:

- Enter your name / signature and date.
- On behalf of:  
State 'as per A1 above' or add full operator onshore address and postcode.

The special waste consignment note is a recognised waste note, from producer point to onshore transfer station.

In order to take best advantage of the SWCN it is advisable to use the special waste pick list (cut and paste option).

This can be provided on request from the EBA via the waste helpline.

Each producer **MUST** hold special waste documentation on file for a minimum of 3 years following transfer.

## Instructions for the Processing of Consignment Notes for Bulk Liquid / Mud Disposals

- Offshore Location shall raise SC consignment note, completing sections A, B and D1 and provide a waste analysis report to the UKOOA standard.
- Offshore Location must retain the **WHITE** copy for files and pass all other copies to the Vessel Master.



## How to Complete the Non-Special Waste Transfer Note

The non-special waste note has sections that must be completed by the Producer. These are highlighted in yellow.

- Complete sections as highlighted in yellow. (see figure 5, page 12)
- For waste descriptions use the 'Non-Special Waste Reference List' to identify and enter EWC codes next to the waste streams being shipped.
- Sign & date the form.
- Retain the white copy of the form.
- Hand the rest of the form to the Ship's Master.

## Control of Pollution (by garbage) at Sea Regulations

Regulated by the MCA (Marine Coastguard Agency) all Offshore Units (Drill Rigs / Platforms / FPSO's) are required to display a WASTE MANAGEMENT PLAN that outlines Roles & Responsibilities; lists waste streams generated; shows a WASTE LOCATOR PLAN which designates main collection points onboard. In addition, the regulations require that a record of all waste generated and sent ashore for disposal is kept on file (copies of waste notes and attachments will suffice).

It is a requirement for placards to be on display advising that 'NO WASTE IS TO BE THROWN OVERBOARD' and you may get stickers from Enviroco to place on external exit points.

An initial 'Starter Pack' including waste consignment notes / reference sheets / posters etc will be provided by the assigned EBA / Offshore Waste Coordinator.

## Packaging of Waste

In accordance with Industry 'Best Practice', black plastic sacks must not be used for waste collection and clear plastic degradable / bio degradable / standard must be used instead. This is necessary to 'spot the hazard' through the waste handling chain. Safety for all is paramount!

Deck crew must follow the Oil & Gas 'Guidelines for the Safe Packing and Handling of Cargo to and from Offshore Locations' and persons preparing manifests and special waste consignment notes must be vigilant and aware of the packing requirements under IMDG (dictated by the UN number classification). For significant volumes of non routine waste please ensure that you are aware of the correct option for containment required both legally but also dictated by the potential end disposal route, to avoid any costly repackaging work.

## Basic Tips for Collecting Waste Onboard

### Batteries –

- Tape over terminals.
- Package lithium batteries individually in clear plastic and with a non-conductive media, i.e. micafil.
- Never specify as non-special.
- Consider rechargeable batteries where possible to reduce waste.

**Fluorescent tubes / Sodium lamps** – Avoid breakage for maximum recycle recovery. Send back in original packaging where possible.

**Food Waste** – Use the onboard galley macerator to dispose of unwanted food stuff. Food residues that cannot be disposed of in this manner must be bagged in clear sacks, sealed and placed in the galley waste skip.

**Aerosols** – Unwanted aerosols must be kept secure and out of direct sunlight. Use smaller containment units rather than a 205 litre clip top drum and transfer ashore to avoid dangerous waste build up onboard.

**Paint Tins** – Empty paint tins must be completely empty and without aroma to be classified as non-special.

**Plastic / Glass Containers** – All containers should be rinsed to ensure they can be recycled. If containers previously contained hazardous products and have not been cleaned, please class as special waste.

All waste is checked on arrival at the registered waste transfer station by a chemist. Non-compliant waste may be reported as a non conformance to the Operator or as an 'observation' depending on the issue. There is a lawful requirement to reject / report non-compliant waste deliveries so deck crew and materials controller vigilance is imperative.

Provide advance notice of any loads of the following waste types to ensure a disposal / recycling route can be found / arranged – LSA, PCB, Flares, Smoke Detectors, large volumes of Mercury and significant volumes of any other non routine waste.

The onshore regulatory authority is the Scottish Environment Agency and they operate in order to regulate the Specil Waste Regulations, the Environmental Protection Act and the Duty of Care.

**Remember use the waste helpline if you are unsure**

## Special and Non-Special Waste Reference Lists

### Special Waste Reference Sheet Pick List

Enviroco have developed waste reference lists for Non-Special and Special wastes. These have been created to assist you in identifying your waste and therefore completing the associated documentation correctly.





















The lists contain comprehensive information including the detail required for the "Description of the Waste" (see page 9) section on Special Waste Documentation. The Special Waste Reference Sheet Pick List has columns included for waste weight, unit size, quantity and container number so that the list can be used as an attachment to a consignment note where there are several items to be consigned. (cut & paste to suit waste streams being sent ashore)

These lists are reviewed frequently to ensure they are up to date and are available from the Environmental Business Advisor (EBA) and on the Enviroco website.

### "What Waste Where" Guide – Special Wastes













The following is a guide as to how to contain your Special wastes. If in doubt please ask your Materials Controller / Deck Foreman or use the NNS waste helpline.

The Carriage of Dangerous Goods Regulations (IMDG) will dictate the packaging classification and labelling.

Waste	Place In	Hazard Info	Limits
Aerosols		Flammable Harmful Toxic	No pesticide aerosols.
Batteries, Alkaline Dry & Batteries Ni-Cad Dry		Corrosive	"Household" type batteries only. Keep different batteries in separate marked containers. Tape terminals.
Batteries, Lead Acid, or Ni-Cad Batteries		Corrosive	Ensure any leaking batteries are held separately. Keep lead acid batteries away from Ni-Cad batteries.
Oil		Potentially Carcinogenic	No oils containing PCBs. Use the helpline if you have PCB contamination.
Paint and Thinners Slops		Flammable Harmful	Drained paint and thinners only. No hardeners, activators or Isocyanates. It is preferable to collect waste paint & thinners separately.
Paint Tins, Drained & Empty	 	Flammable Harmful	Ensure that a liner bag is used or please bag your tins.
Rags Contaminated with Oil	 	Potentially Carcinogenic	No free liquids. Ensure that a liner bag is used or please bag. Specify on paperwork if they are recyclable trial rags.
Medical Waste – Sharps		Infectious Substance	Used sharps only.
Medical Waste – Swabs / Dressings		Infectious Substance	Use a rigid clinical waste container.
Gaskets – Asbestos	 	Potentially Carcinogenic	Gaskets are not accepted as scrap. Assume all gaskets contain asbestos. Gaskets must be double bagged and then drummed.
Hazardous Liquids	 	Flammable Corrosive Toxic	Ensure that materials are not mixed together and a detailed description/MSDS is added to the paperwork.
Hazardous Solids	 	Flammable Corrosive Toxic	Ensure that materials are not mixed together and a detailed description/MSDS is added to the paperwork.
Gas Cylinders		Flammable Corrosive Toxic	Ensure a detailed description is added to the paperwork. Specify if your cylinder is de-gassed and tag accordingly. Do not put in scrap metal skip.
Fluorescent Tubes		Mercury Vapours	Return complete. Do not break.
Fridges & Freezers, TV's & Electrical Compliances		Toxic Gases	Return as itemised WEEE.

















## “What Waste Where” Guide – Non-Special Wastes

The following is a guide as to how to contain your Non-Special wastes. If in doubt please ask your Materials Controller/Deck Forman or use the NNS waste helpline.

Waste	Place In	Limits
Galley Waste		Non recyclable and bagged waste only.
Scrap Metal		No gas cylinders. No general waste. No gaskets. No aerosols. No hazardous/special waste. No pallets or wood.
Paper & Cardboard		Paper & card can be placed in these containers. Wheelie bins are available for loose paper/card. (Do not include contaminated wood)
Timber		Timber of all sorts can be recycled. Remove potential safety hazards if possible.
Plastics		Plastic bottles can be recycled. Good quality shrink-wrap/bubblewrap/polythene* (soft plastics) can be recycled. These must not be packaged together. All plastic must be clean and free of contamination.
General Waste		Remember to bag as much as possible with clear bin bags and place them in waste skips.
Plastic Cups		Ensure all liquids are removed from the cups. Use the Becca Bins provided and bag the stacks of cups into clear plastic bags.
Glass		All glass can be recycled. Use wheelie bins or clip-top drums to contain the material. Rinse out bottles and jars first (Do not include crockery). Segregate by colour where possible.
Empty Drums		Make sure all contents are removed. If residue remains then consign as hazardous/special waste. Specify on paperwork whether plastic or metal.
Cooking Oil		Cooking oil can be recycled and should not be mixed with mineral oils.
Water Based Drilling Mud's / Brine		Make sure that the description used reflects the type of mud being carried. Oil based mud is hazardous/special waste, so will require a consignment note.
WEEE (Non-Special)		Electrical components can be recycled and need to be packaged separately from general wastes/scrap metal skips. Check reference lists, as some are hazardous/special waste eg. fridges

## “What Waste Where” Guide – Key

### Container Types

Container Type	Description	Container Type	Description
	200 litre Clip-top (Open Head) Drum		10x8 Offshore Specification Open Half-height Container
	25 litre Clip-top (Open Head) Pail		Half-height Container or Cargo Basket with Access Gate
	Battery Safe / Box		6.1 Cu. M Recycle Unit Waste Cube (Also in Red / Blue)
	25>200 litre Bung-top Drum		1100 litre Wheelie Bin
	800 litre Waste Safe Note: No lifting points for lift pockets only		Clear Refuse Sack
	9 litre Sharps Bin		2.5 Metre Fluorescent Tube Box
	Rigid Clinical Waste Container		Gas Cylinder Rack
	25 litre Asbestos Sack		500 Gallon (2200 litre) IMO Tote Tank

## CROSS INDUSTRY WORKGROUP

The cross industry workgroup consisted of members from the following companies:

Paul Logue – Chairman

ASCO Group

Regent Centre

Regent Road

Aberdeen

AB11 5NS

Tel:+44 (0) 1224 371182 / 587044



Euan Simpson & Ken Noble

ASCO Group

Regent Centre

Regent Road

Aberdeen

AB11 5NS

Tel:+44 (0) 1224 371182 / 587044



Gary Florence

BP

1 Wellheads Avenue

Dyce

Aberdeen

AB21 7PB

Tel:+44 (0) 1224 832000



Derek Birse

Britannia Operator Ltd

Royfold House

Hill of Rubislaw

Aberdeen

AB15 6GZ

Tel:+44 (0) 1224 327100



**Britannia**  
Operator Ltd

Ali Davis

EnerMech Ltd

EnerMech House,

Howes Road

Aberdeen

AB16 7AG

Tel:+44 (0) 1224 723300



## CROSS INDUSTRY WORKGROUP

The cross industry workgroup consisted of members from the following companies:

<p>Mike Close DNV – GL Oil &amp; Gas No 1 The Exchange, 62 Market Street, Aberdeen AB11 5PJ, Tel:+44 (0) 1224 289100</p>	
<p>David Morrison Nexen Petroleum U.K. Limited Discovery House, Prime Four Business Park. Kingswells Causeway Kingswells Industrial Estate Aberdeen, AB15 8PU Tel:+44 (0) 1224 371537</p>	
<p>Keith Dawson Peterson Nautilus House 35 Waterloo Quay Aberdeen AB11 5BS Tel:+44 (0) 1224 288100</p>	
<p>Jacqueline Alexander &amp; Kenneth Lawtie Shell UK Limited 1 Altens Farm Road Nigg Aberdeen AB12 3FY Tel:+44 (0) 1224 881483 / 778515</p>	
<p>Mike Coull Statoil Production (UK) Limited 15 Chapel Street Aberdeen AB10 1SQ Tel: 07557 283719</p>	

## CROSS INDUSTRY WORKGROUP

The cross industry workgroup consisted of members from the following companies:

Neil Moir  
Swire Oilfield Services  
Swire House  
Souter Head Road, Altens  
Aberdeen, Scotland, AB12 3LF  
Tel:+44 (0) 1224 872707



Bert Van Eyck  
Talisman Sinopec Energy UK Ltd.  
Talisman House  
163 Holburn Street  
Aberdeen  
AB10 6BZ  
Tel:+44 (0) 1224 352500



Chris Coull  
TAQA Bratani  
Limited Prospect Road,  
Westhill,  
Aberdeenshire  
AB32 6FE  
Tel:+44 (0) 1224 202869 ext 6968



Glen Bryant  
Total E&P UK Limited  
Crawpeel Road  
Altens  
Aberdeen  
AB12 3FG  
Tel:+44 (0) 1224 297000



## FEEDBACK

Please give your feedback on the document to enable improvements to be made.

Visit [www.onshoreoffshorecargo.com](http://www.onshoreoffshorecargo.com) for feedback.

## RECOGNITION

Many people were involved in the development and review of this document, however we would particularly like to recognise and acknowledge the contribution of the following people:

Paul Logue (Chairman)	ASCO
Ali Davis	EnerMech Ltd
Bert Van Eyck	Talisman Sinopec Energy UK Ltd.
Chris Coull	TAQA
David Morrison	Nexen Petroleum U.K. Limited
Derek Birse	Britannia Operator Ltd.
Euan Simpson	ASCO Marine
Gary Florence	BP
Glen Bryant	Total E&P UK plc
Jacqueline Alexander	Shell UK Limited
Keith Dawson	Peterson
Ken Noble	ASCO
Kenneth Lawtie	Shell UK Limited
Mike Close	DNV – GL Oil & Gas
Mike Coull	Statoil
Neil Moir	Swire Oilfield Services

## THANK YOU ALSO TO:

Gregor Gibb  
AquaTerra



Julian Foley  
Enviroco



Billy Lamont & Derek Emslie  
lamontdesign

lamontdesign:

Andrew Green  
Survivex Ltd



## SPECIAL RECOGNITION:

Kenny LeTissier  
Halliburton

Simon Jones  
Mentor Aviation

Phil Murray  
TAQA

Marc Gater  
Fairfield



## **Best Practice for the Safe Packing & Handling of Cargo to & from Offshore Locations**

This Best Practice document has been compiled following extensive research and input from cross industry participants. It is intended to convey the key aspects of Safe Packing & Handling of Cargo to and from Offshore Locations in a format which is easily understood and applied. Where appropriate, the relevant legislation or source of information has been referenced. Our industry is now over forty years old, so it is imperative that we eradicate all safety risks.

**The document is designed for use by you;  
please use it wisely.**

